



US009450039B2

(12) **United States Patent**
Jeong et al.

(10) **Patent No.:** **US 9,450,039 B2**
(45) **Date of Patent:** **Sep. 20, 2016**

(54) **ORGANIC LIGHT EMITTING DISPLAY APPARATUS AND METHOD OF MANUFACTURING THE SAME**

(71) Applicant: **SAMSUNG DISPLAY CO., LTD.**,
Yongin, Gyeonggi-Do (KR)
(72) Inventors: **Byoung-Seong Jeong**, Yongin (KR);
Sang-Yeol Kim, Yongin (KR);
Seung-Wook Chang, Yongin (KR);
Se-Ho Lee, Yongin (KR); **Tae-Hyung Kim**, Yongin (KR)

(73) Assignee: **SAMSUNG DISPLAY CO., LTD.**,
Yogin-Si, Gyeonggi-Do (KR)

(*) Notice: Subject to any disclaimer, the term of this patent is extended or adjusted under 35 U.S.C. 154(b) by 0 days.

(21) Appl. No.: **14/479,047**

(22) Filed: **Sep. 5, 2014**

(65) **Prior Publication Data**
US 2014/0374732 A1 Dec. 25, 2014

Related U.S. Application Data
(63) Continuation-in-part of application No. 14/012,725, filed on Aug. 28, 2013.

(30) **Foreign Application Priority Data**
May 31, 2013 (KR) 10-2013-0063082
May 30, 2014 (KR) 10-2014-0066528

(51) **Int. Cl.**
H01L 27/32 (2006.01)
H01L 51/52 (2006.01)

(52) **U.S. Cl.**
CPC **H01L 27/3276** (2013.01); **H01L 27/3246** (2013.01); **H01L 51/5228** (2013.01)

(58) **Field of Classification Search**
CPC H01L 27/3276; H01L 27/3246; H01L 51/5228

See application file for complete search history.

(56) **References Cited**

U.S. PATENT DOCUMENTS

6,995,035 B2 2/2006 Cok et al.
7,915,811 B2 3/2011 Kang et al.
2005/0179374 A1 8/2005 Kwak
2008/0284323 A1* 11/2008 Kashiwabara H01L 51/5203 313/504
2009/0295282 A1 12/2009 Yoon et al.
2012/0104941 A1* 5/2012 Jung C07D 239/26 313/504

FOREIGN PATENT DOCUMENTS

JP 2005-11810 1/2005
KR 10-2000-065703 11/2000
KR 10-2004-0106058 12/2004
KR 2005-0027464 3/2005

OTHER PUBLICATIONS

Office Action issued by the Korean Intellectual Property Office on Aug. 7, 2015 in the examination of the Korean Patent Application No. 10-2014-0066528.

* cited by examiner

Primary Examiner — Anne Hines
(74) *Attorney, Agent, or Firm* — Knobbe, Martens, Olson & Bear LLP
(57)

ABSTRACT

An organic light emitting display apparatus and a method of manufacturing the same are disclosed. The organic light emitting display apparatus includes, for example, a bus electrode, an insulating layer covering the bus electrode and having a bus electrode hole exposing at least a part of the bus electrode, a pixel electrode formed on the insulating layer and electrically coupled with the bus electrode, a pixel defining layer exposing a part of the pixel electrode and a part of the bus electrode, a first intermediate layer on the pixel defining layer and the pixel electrode, the first intermediate layer having a first opening to expose the part of the bus electrode, an emission layer disposed on the first intermediate layer, and an opposite electrode to correspond to the pixel electrode and the bus electrode and contacting the bus electrode through the first opening and the bus electrode hole.

32 Claims, 16 Drawing Sheets

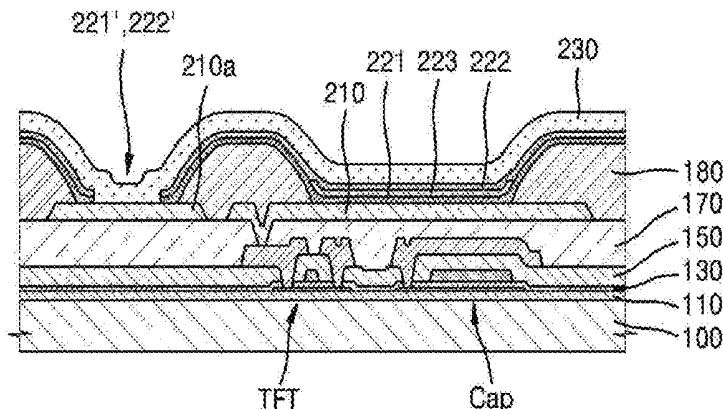

FIG. 1

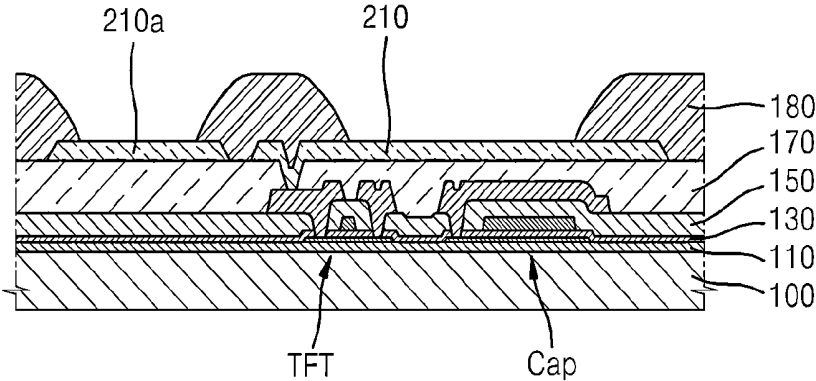

FIG. 2

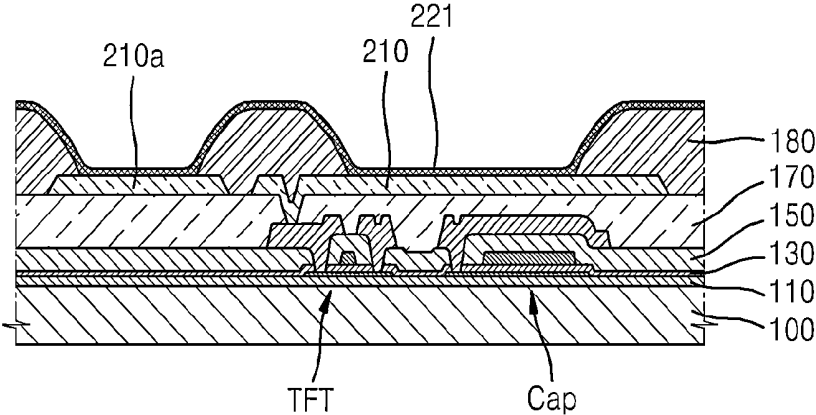

FIG. 3

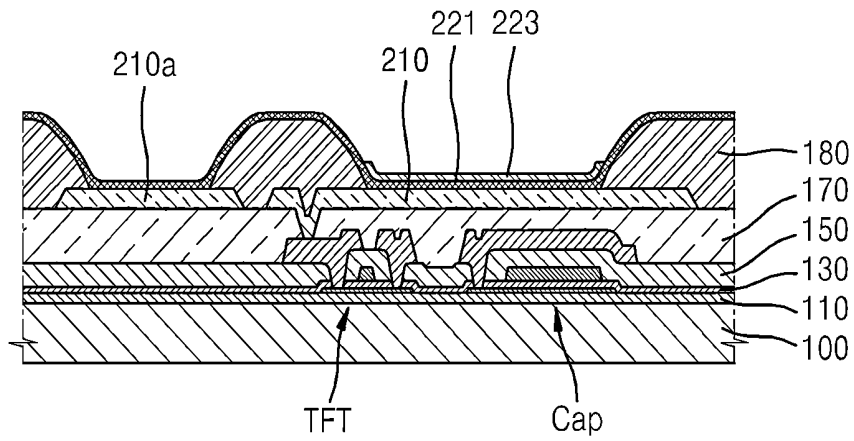

FIG. 4

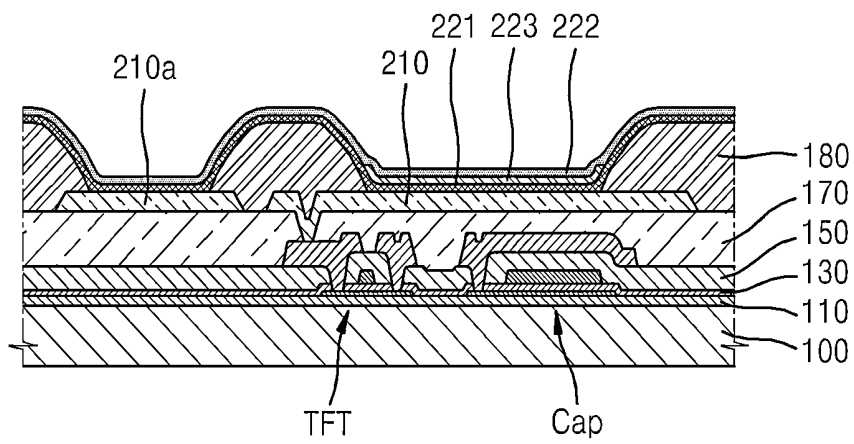

FIG. 5

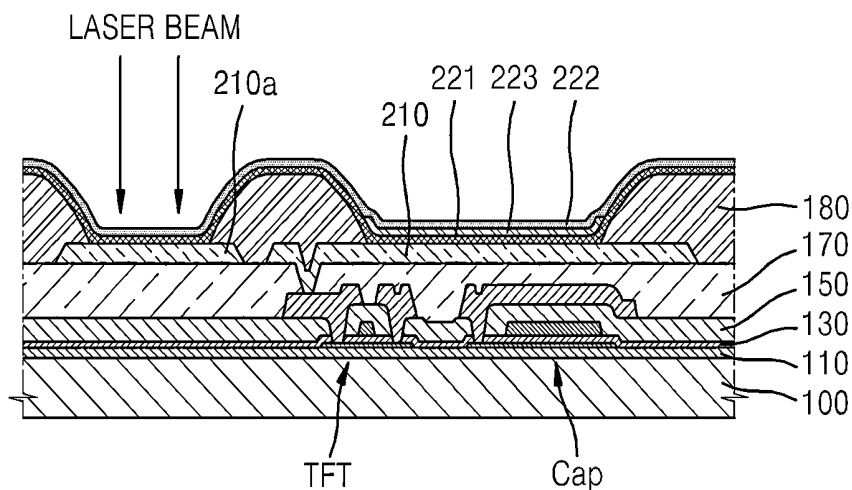

FIG. 6

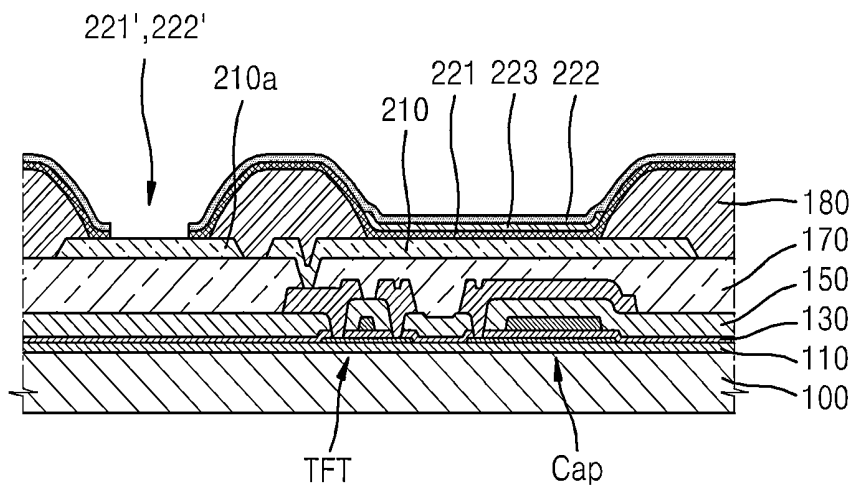

FIG. 9

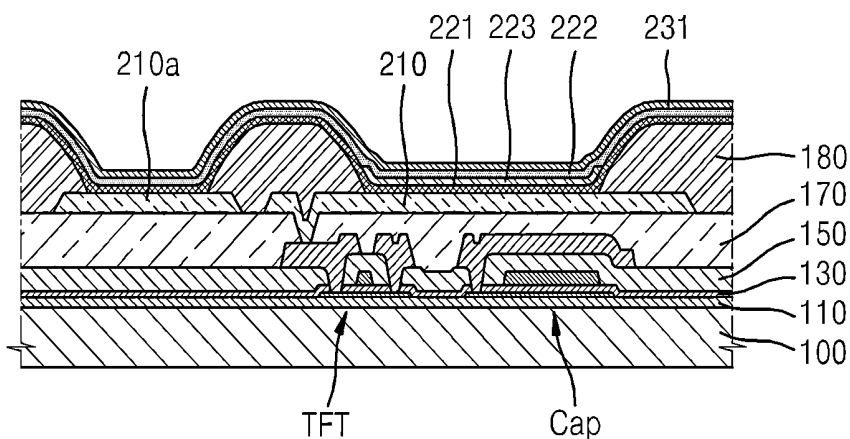

FIG. 10

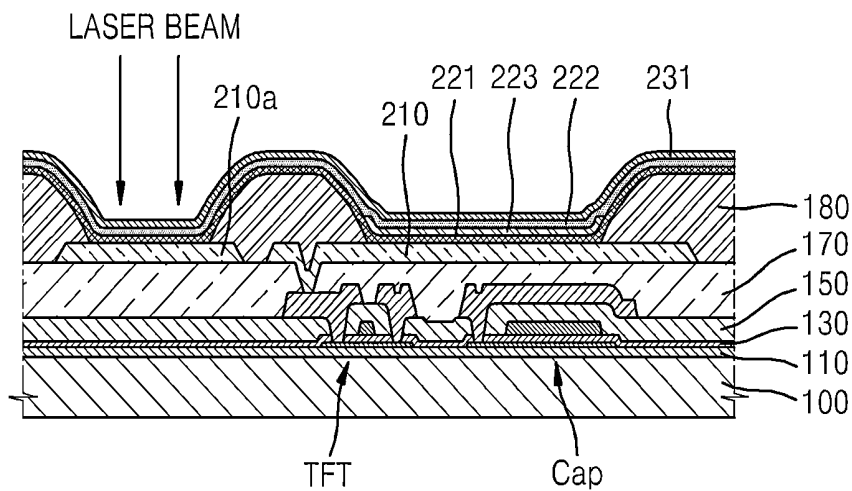

FIG. 11

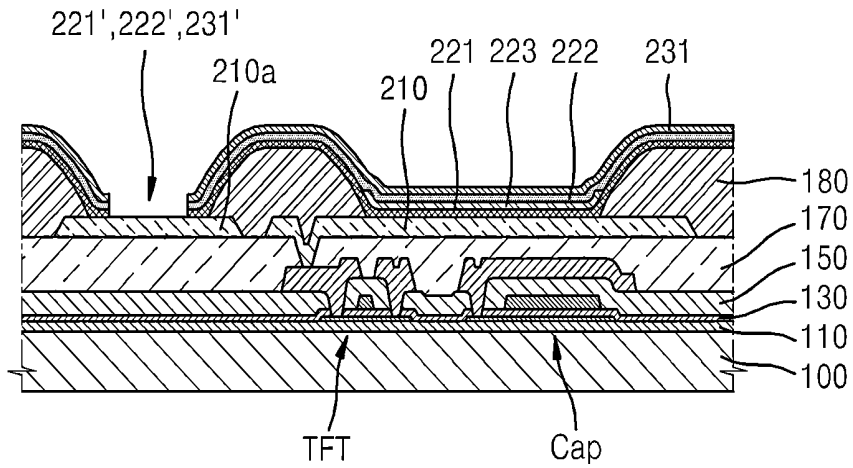

FIG. 12

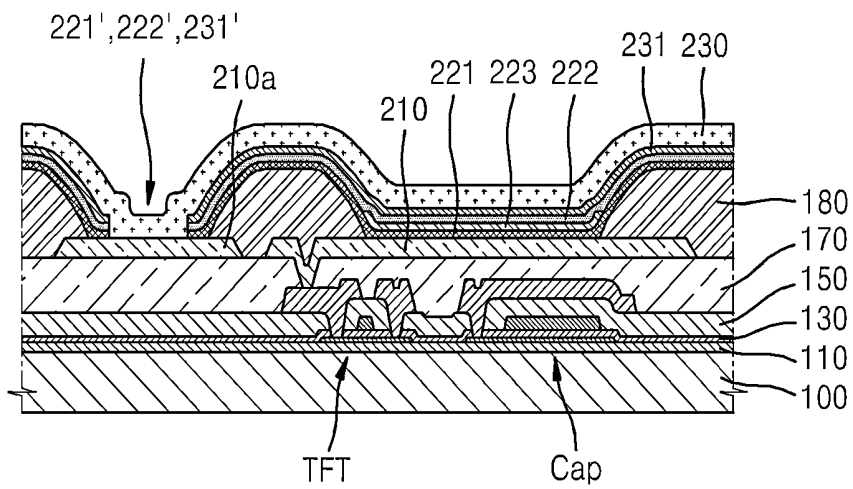

FIG. 13

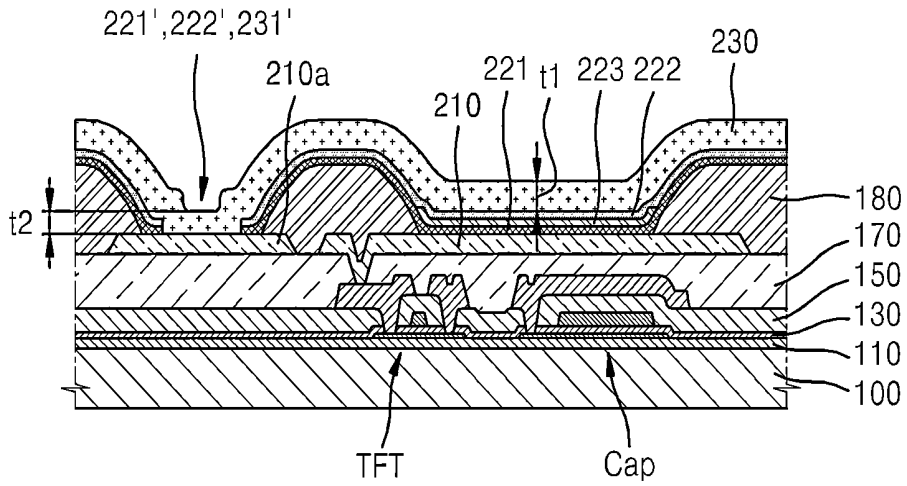

FIG. 14

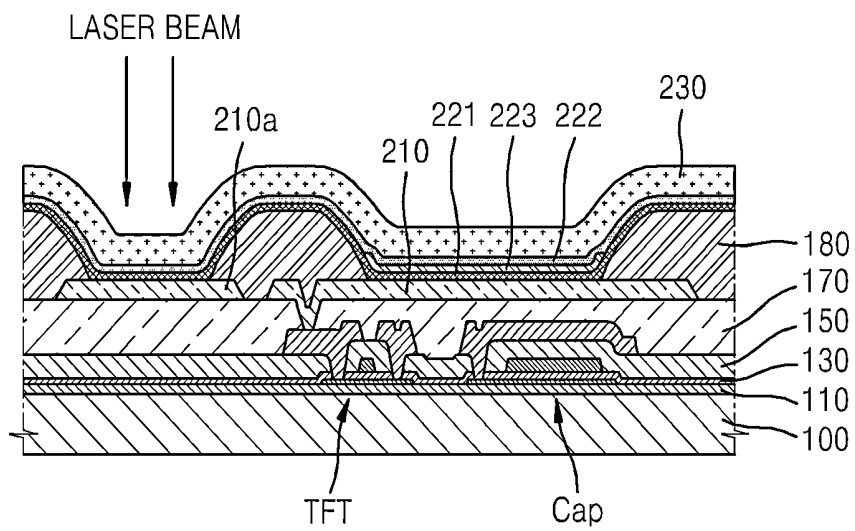

FIG. 15

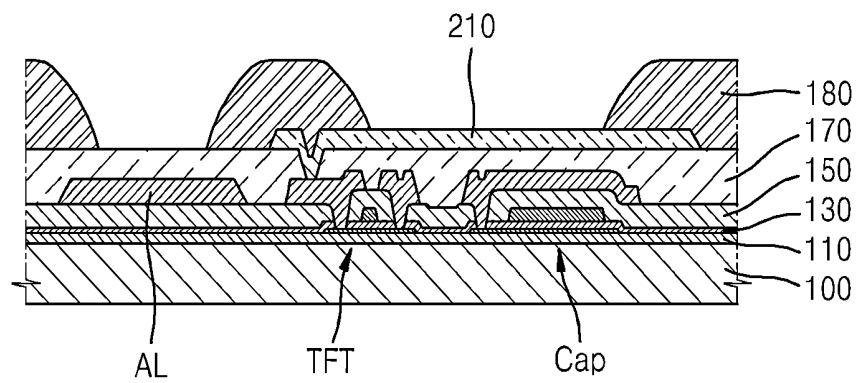

FIG. 16

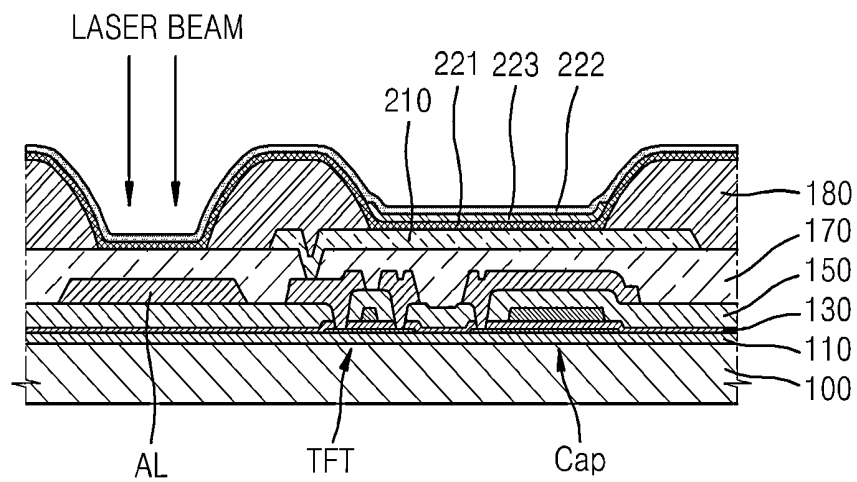

FIG. 17

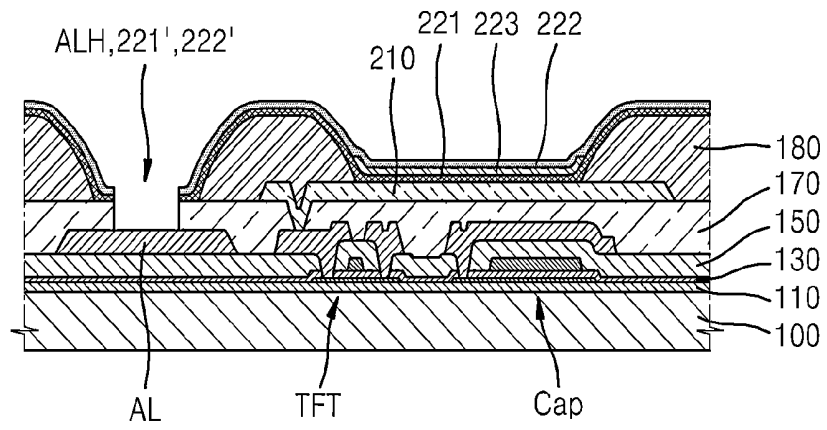

FIG. 18

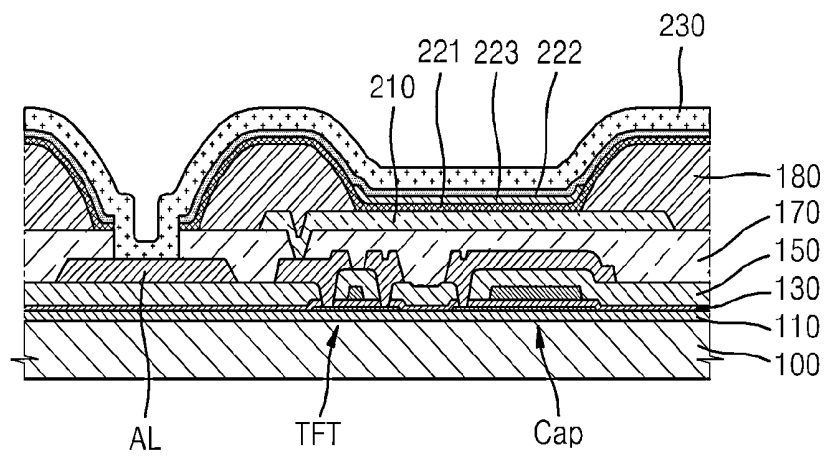

FIG. 19

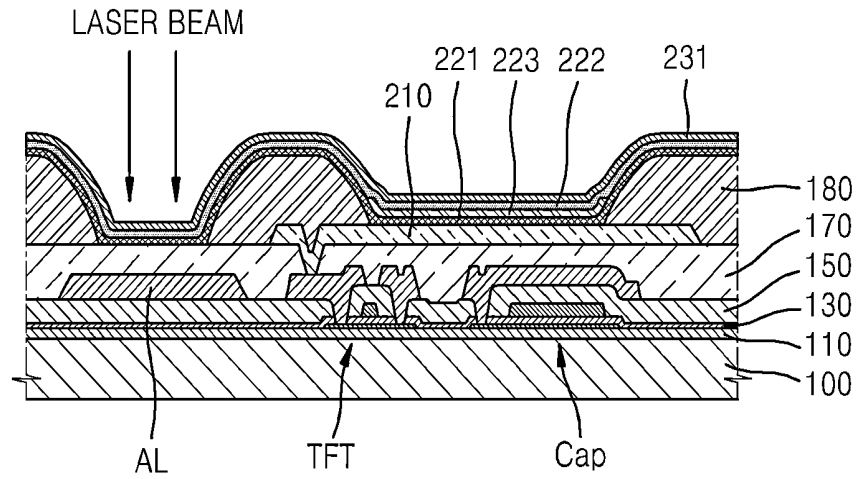

FIG. 20

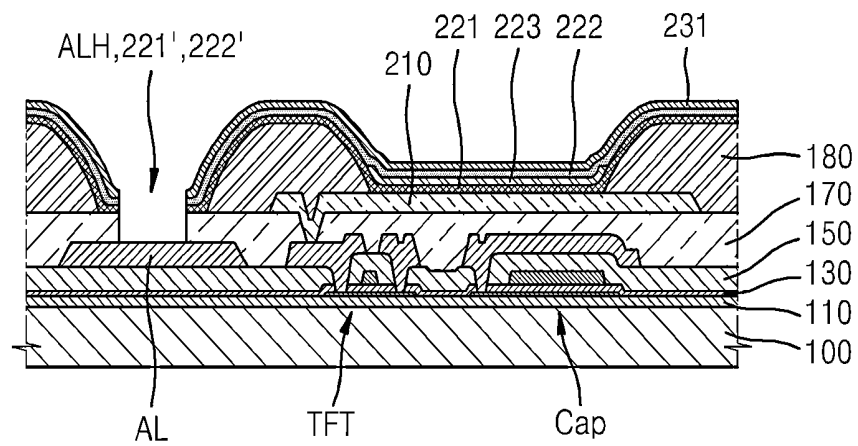

FIG. 21

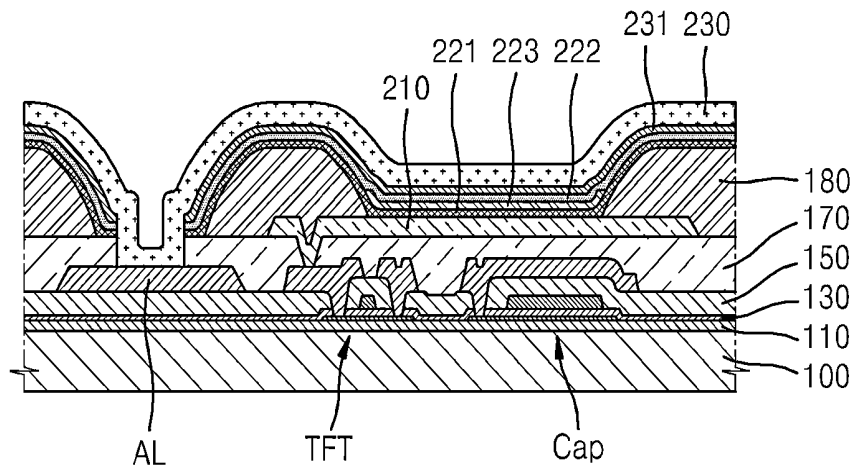

FIG. 22

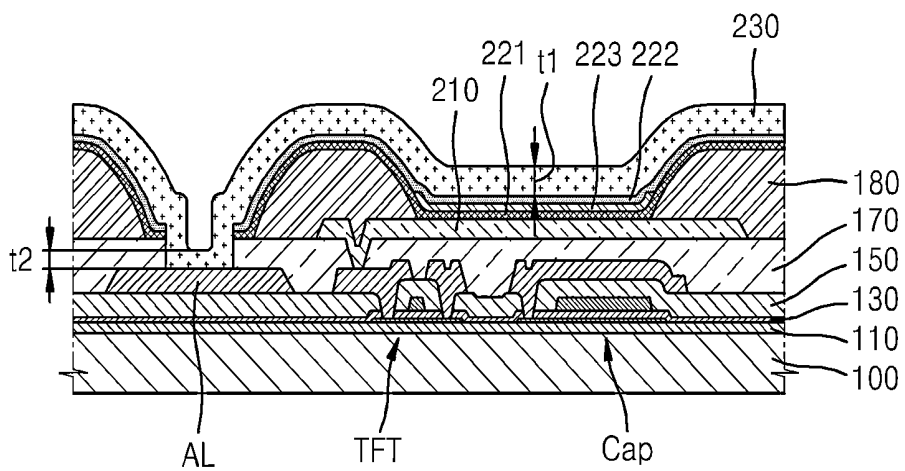

FIG. 23

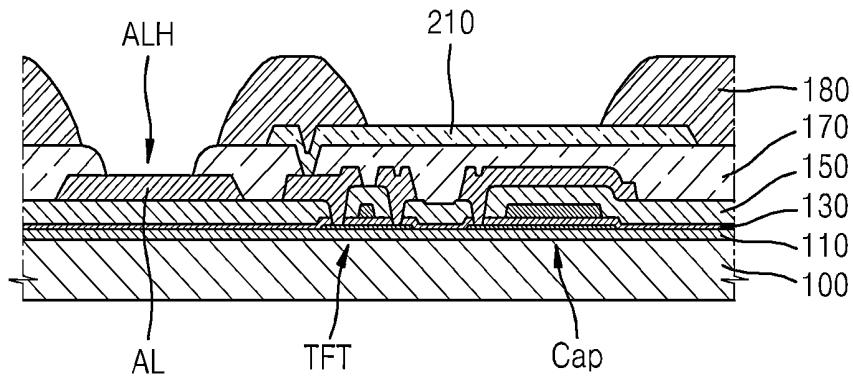

FIG. 24

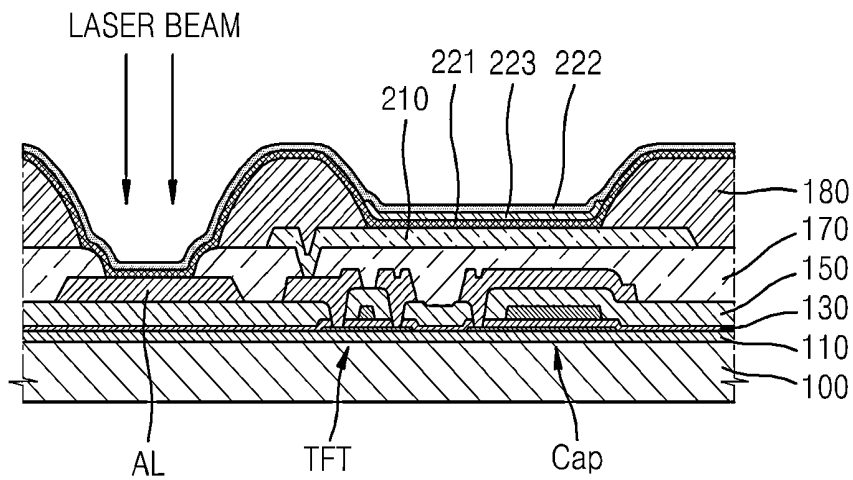

FIG. 25

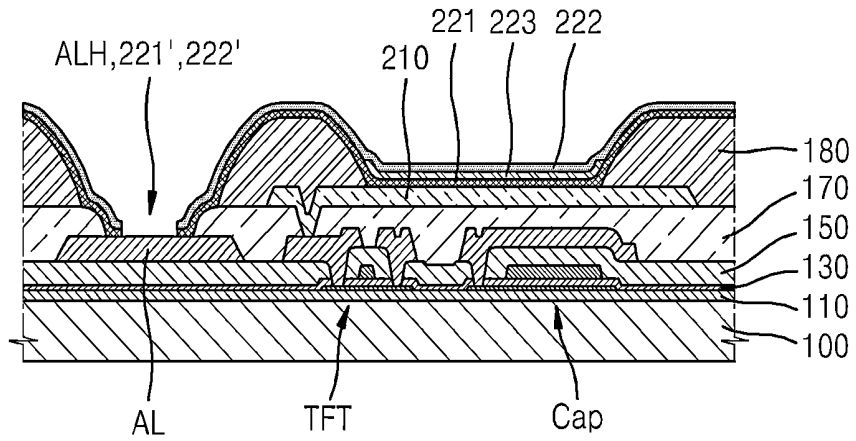

FIG. 26

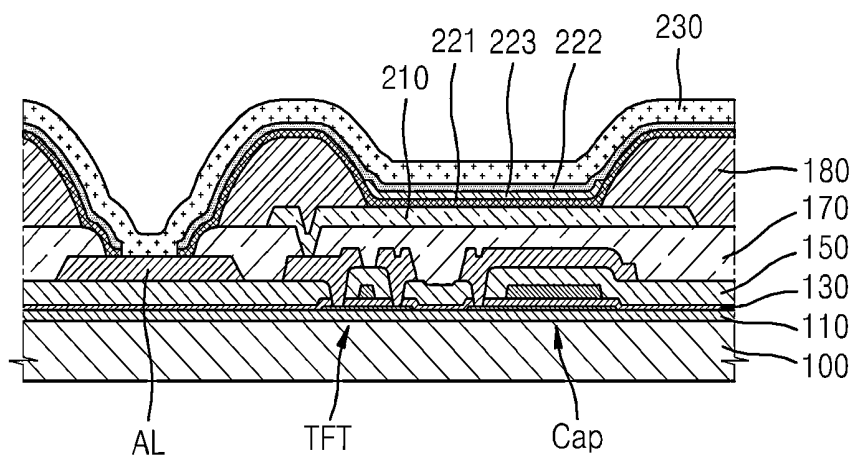

FIG. 27

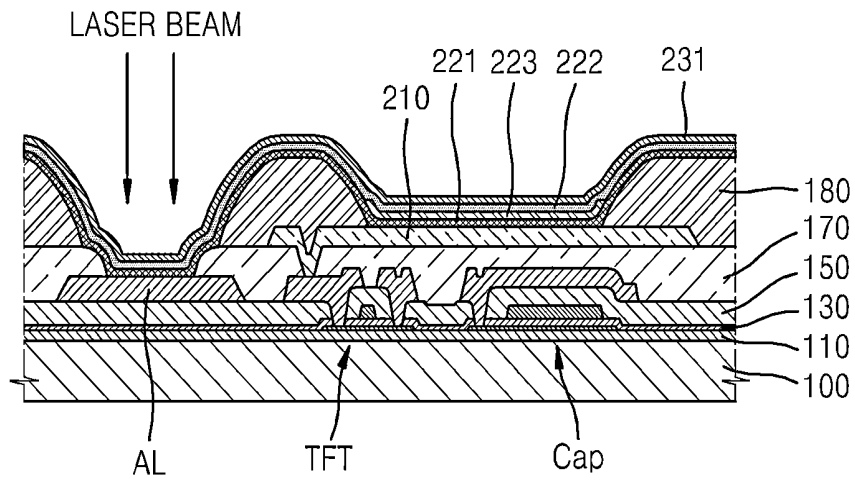

FIG. 28

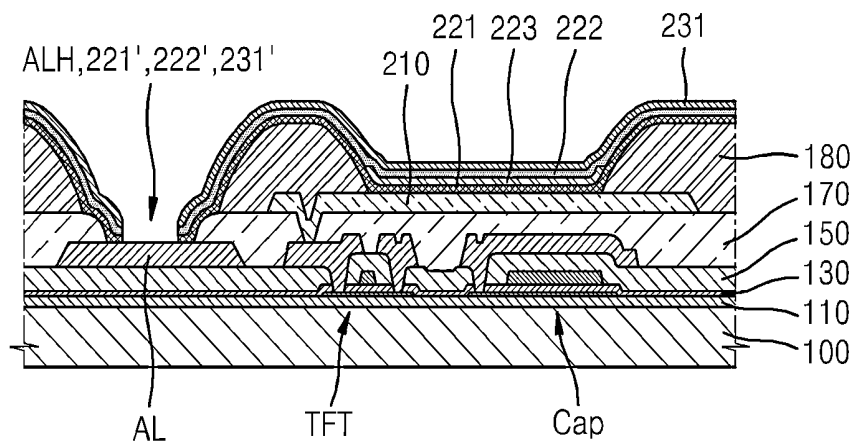

FIG. 31

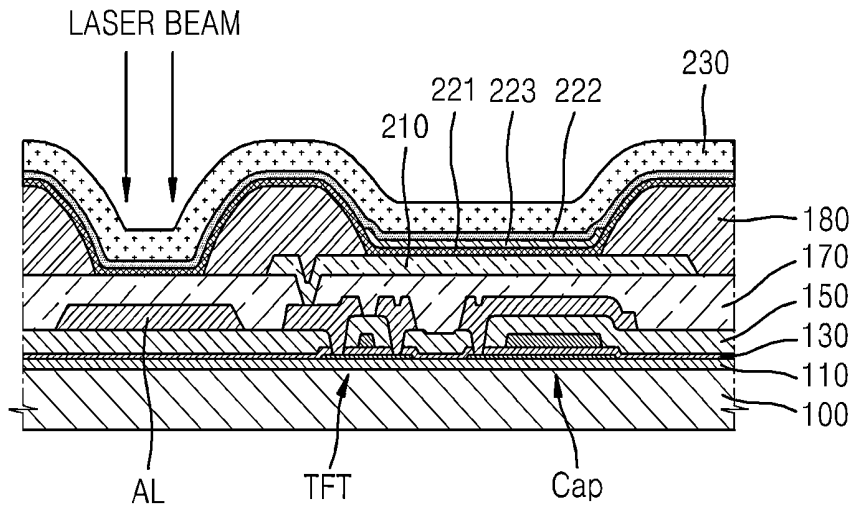
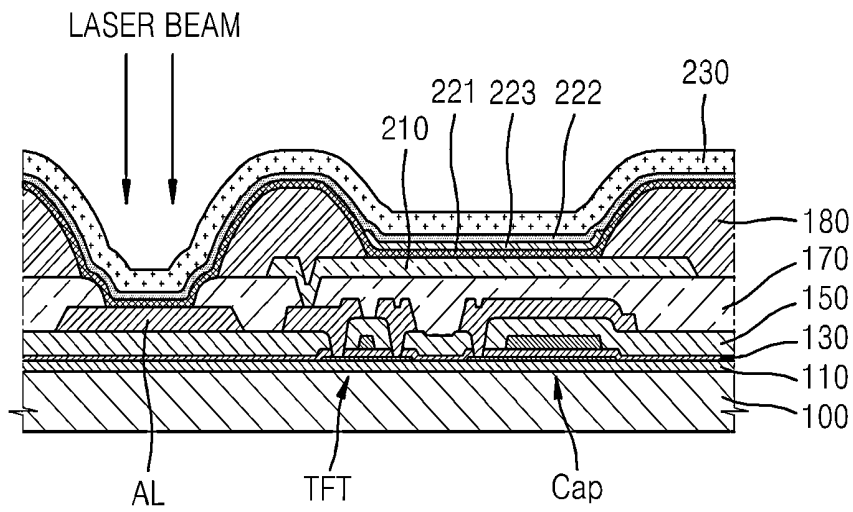

FIG. 32



**ORGANIC LIGHT EMITTING DISPLAY
APPARATUS AND METHOD OF
MANUFACTURING THE SAME**

INCORPORATION BY REFERENCE TO ANY
PRIORITY APPLICATIONS

Any and all applications for which a foreign or domestic priority claim is identified in the Application Data Sheet as filed with the present application are hereby incorporated by reference under 37 CFR 1.57. For example, this application is a continuation-in-part of U.S. application Ser. No. 14/012,725, filed on Aug. 28, 2013, which claims the benefit of Korean Patent Application No. 10-2013-0063082, filed on May 31, 2013, in the Korean Intellectual Property Office, the disclosure of each of which is incorporated herein in its entirety by reference. Further, this application claims the benefit of Korean Patent Application No. 10-2014-0066528, filed on May 30, 2014, the disclosure of which is incorporated herein in its entirety by reference.

BACKGROUND

1. Field

The present disclosure relates to an organic light emitting display apparatus and a method of manufacturing the same, and more particularly, to an organic light emitting display apparatus that may be easily manufactured and has high brightness stability, and a method of manufacturing the same.

2. Description of the Related Technology

Organic light emitting displays have a plurality of pixels, each pixel including an organic light emitting device. The organic light emitting device has a pixel electrode, an opposite electrode facing the pixel electrode, and an intermediate layer interposed between the pixel electrode and the opposite electrode and including an emission layer (EML). The pixel electrode is patterned in each pixel in an island shape, and the opposite electrode is formed integral to the plurality of pixels. However, in some organic light emitting display apparatuses, an IR drop occurs in the opposite electrode and an unintended brightness difference occurs in the plurality of pixels.

SUMMARY OF CERTAIN INVENTIVE
ASPECTS

In one aspect, an organic light emitting display apparatus is provided that may be easily manufactured and has high luminous stability.

In another aspect, a method of manufacturing an organic light emitting display apparatus is provided.

In another aspect, an organic light emitting display apparatus is provided, including, for example, a bus electrode, an insulating layer covering the bus electrode and having a bus electrode hole so that at least a part of the bus electrode is exposed through the bus electrode hole, a pixel electrode formed on the insulating layer and electrically coupled with the bus electrode, a pixel defining layer formed on the insulating layer so that at least a part of the pixel electrode including a central part thereof and at least the part of the bus electrode exposed through the bus electrode hole are exposed, a first intermediate layer formed on the pixel defining layer and the pixel electrode, the first intermediate layer having a first opening corresponding to the bus electrode hole of the insulating layer so that at least the part of the bus electrode is exposed, an emission layer formed on the first

intermediate layer to correspond to the pixel electrode, and an opposite electrode formed on the emission layer to correspond to the pixel electrode and the bus electrode, the opposite electrode contacting the bus electrode through the first opening of the first intermediate layer and the bus electrode hole of the insulating layer.

In some embodiments, the organic light emitting display apparatus may further comprise a thin film transistor including a source electrode, a drain electrode, and the gate electrode, wherein the bus electrode is on a same layer as at least one of the source electrode, drain electrode, and the gate electrode. In some embodiments, the source electrode and the drain electrode are located above the gate electrode, and the bus electrode is on a same layer as the source electrode and the drain electrode. In some embodiments, the first opening of the first intermediate layer exposes only a part of the bus electrode. In some embodiments, a portion of the first intermediate layer adjacent to the first opening may be a portion deteriorated through exposure to high-temperature heat. In some embodiments, the organic light emitting display apparatus may further include an auxiliary opposite electrode formed on a surface toward the first intermediate layer of the opposite electrode to contact the opposite electrode, the auxiliary opposite electrode having a third opening corresponding to the first opening of the first intermediate layer. In some embodiments, a thickness of the auxiliary opposite electrode may be smaller than the thickness of the opposite electrode. In some embodiments, the auxiliary opposite electrode may correspond to the opposite electrode in a portion of the first intermediate layer not including the first opening. In some embodiments, a thickness of a portion of the opposite electrode corresponding to the first opening of the first intermediate layer may be smaller than the thickness of another portion of the opposite electrode.

In some embodiments, the organic light emitting display apparatus may further include a second intermediate layer formed between the first intermediate layer and the opposite electrode to cover the first intermediate layer and the emission layer. In some embodiments, the second intermediate layer has a second opening corresponding to the first opening of the first intermediate layer so that the opposite electrode contacts the bus electrode through the first opening and the second opening. In some embodiments, the second opening may be larger than the first opening. In some embodiments, a center of the second opening and a center of the first opening are substantially aligned with each other when viewed in a direction substantially normal to the first and the second opening. In some embodiments, a portion of the second intermediate layer adjacent to the second opening may be a portion that is deteriorated by exposure to heat. In some embodiments, the second intermediate layer may include at least one of LiF and Liq.

In another aspect, a method of manufacturing an organic light emitting display apparatus is provided that includes, for example, forming a bus electrode, forming an insulating layer covering the bus electrode, forming a pixel electrode on the insulating layer, forming a pixel defining layer on the insulating layer so that at least a part of the pixel electrode including a central part thereof is exposed, forming a first intermediate layer on the pixel defining layer and the pixel electrode, forming an emission layer on the first intermediate layer to correspond to the pixel electrode, exposing at least a part of the bus electrode, and forming an opposite electrode corresponding to the pixel electrode and the bus electrode to contact the bus electrode.

In some embodiments, the forming of the bus electrode comprises forming the bus electrode on a same layer as at least one of a source electrode, a drain electrode, and a gate electrode of a thin film transistor. In some embodiments, the method may further comprise forming a bus electrode hole exposing at least the part of the bus electrode by removing at least a portion of the insulating layer corresponding to the bus electrode, wherein the forming of the pixel defining layer comprises forming the pixel defining layer on the insulating layer so that at least the part of the bus electrode exposed through the bus electrode hole is exposed, wherein the forming of the first intermediate layer comprises forming the first intermediate layer on the pixel defining layer, the pixel electrode, and the bus electrode, and wherein the exposing at least the part of the bus electrode comprises forming a first opening by removing a portion of the first intermediate layer on the bus electrode. In some embodiments, the forming of the first opening may include forming the first opening through which only a part of the bus electrode is exposed.

In some embodiments, the forming of the first opening may be achieved by irradiating a laser beam onto the first intermediate layer. In some embodiments, the method may further include, between the forming of the emission layer and the forming of the first opening: forming an auxiliary opposite electrode corresponding to the pixel electrode and the bus electrode. In some embodiments, the first opening in the first intermediate layer is formed along with a third opening in the auxiliary opposite electrode by removing a portion of the first intermediate layer on the bus electrode and a portion of the auxiliary opposite electrode on the bus electrode so that at least a part of the bus electrode is exposed. In some embodiments, the opposite electrode is formed to correspond to the pixel electrode and the bus electrode to contact the bus electrode through the first opening in the first intermediate layer and the third opening in the auxiliary opposite electrode. In some embodiments, the first opening in the first intermediate layer and the third opening in the auxiliary opposite electrode may be simultaneously formed by irradiating a laser beam onto the auxiliary opposite electrode. In some embodiments, the opposite electrode may be formed to be thicker than the auxiliary opposite electrode.

In some embodiments, the method may further include, between the forming of the emission layer and the forming of the first opening, forming a second intermediate layer to cover the first intermediate layer and the emission layer. In some embodiments, the first opening in the first intermediate layer is formed along with a second opening in the second intermediate layer by removing a portion of the first intermediate layer on the bus electrode and a portion of the second intermediate layer on the bus electrode so that at least a part of the bus electrode is able to be exposed; and the opposite electrode is formed to correspond to the pixel electrode and the bus electrode to contact the bus electrode through the first opening of the first intermediate layer and the second opening of the second intermediate layer. In some embodiments, the first opening in the first intermediate layer and the second opening in the second intermediate layer may be simultaneously formed by irradiating a laser beam onto the second intermediate layer.

In some embodiments, the forming of the pixel defining layer comprises forming the pixel defining layer on the insulating layer so that at least the part of the pixel electrode including the central part thereof and at least a part of the insulating layer corresponding to the bus electrode are exposed, and wherein the exposing at least the part of the bus

electrode comprises forming a bus electrode hole of the insulating layer and a first opening of the first intermediate layer by removing a portion of the insulating layer on the bus electrode and a portion of the first intermediate layer on the bus electrode so that at least the part of the bus electrode is exposed. In some embodiments, the forming of the bus electrode hole and the first opening comprises irradiating a laser beam onto the first intermediate layer. In some embodiments, the method may further comprise after the forming of the emission layer and before the forming of the bus electrode hole and the first opening, forming an auxiliary opposite electrode corresponding to the pixel electrode and the bus electrode, wherein the forming of the bus electrode hole and the first opening comprises forming a bus electrode hole of the insulating layer, a first opening of the first intermediate layer, and a third opening of the auxiliary opposite electrode by removing a portion of the insulating layer on the bus electrode, a portion of the first intermediate layer on the bus electrode, and a portion of the auxiliary opposite electrode on the bus electrode so that at least the part of the bus electrode is exposed, and wherein the forming of the opposite electrode comprises forming the opposite electrode to correspond to the pixel electrode and the bus electrode to contact the bus electrode through the bus electrode hole in the insulating layer, the first opening in the first intermediate layer, and the third opening in the auxiliary opposite electrode. In some embodiments, the forming of the bus electrode hole, the first opening, and the third opening comprises irradiating a laser beam onto the auxiliary opposite electrode so that the bus electrode hole, the first opening, and the third opening are simultaneously formed. In some embodiments, the opposite electrode is formed to be thicker than the auxiliary opposite electrode.

In some embodiments, the method may further comprise, after the forming of the emission layer and before the forming of the first opening, forming a second intermediate layer to cover the first intermediate layer and the emission layer, wherein the forming of the bus electrode hole and the first opening comprises forming a bus electrode hole of the insulating layer, a first opening of the first intermediate layer, and a second opening of the second intermediate layer by removing a portion of the insulating layer on the bus electrode, a portion of the first intermediate layer on the bus electrode so that at least the part of the bus electrode is exposed, and wherein the forming of the opposite electrode comprises forming the opposite electrode to correspond to the pixel electrode and the bus electrode to contact the bus electrode through the bus electrode hole in the insulating layer, the first opening in the first intermediate layer, and the second opening in the second intermediate layer. In some embodiments, wherein the forming of the bus electrode hole, the first opening, and the second opening comprises irradiating a laser beam onto the second intermediate layer so that the bus electrode hole, the first opening, and the second opening are simultaneously formed.

In another aspect, a method of manufacturing an organic light emitting display apparatus is provided that includes, for example, forming a bus electrode, forming an insulating layer covering the bus electrode, forming a pixel electrode on the insulating layer, forming a pixel defining layer on the insulating layer so that at least a part of the pixel electrode including a central part thereof is exposed, forming a first intermediate layer on the pixel defining layer and the pixel electrode, forming an emission layer on the first intermediate layer to correspond to the pixel electrode, forming an opposite electrode corresponding to the pixel electrode and

the bus electrode, and irradiating a laser beam onto at least a part of the opposite electrode corresponding to the bus electrode so that at least a part of layers between the opposite electrode and the bus electrode is removed and the opposite electrode and the bus electrode contact each other.

BRIEF DESCRIPTION OF THE DRAWINGS

Features of the present disclosure will become more fully apparent from the following description and appended claims, taken in conjunction with the accompanying drawings. It will be understood these drawings depict only certain embodiments in accordance with the disclosure and, therefore, are not to be considered limiting of its scope; the disclosure will be described with additional specificity and detail through use of the accompanying drawings. An apparatus, system or method according to some of the described embodiments can have several aspects, no single one of which necessarily is solely responsible for the desirable attributes of the apparatus, system or method. After considering this discussion, and particularly after reading the section entitled "Detailed Description of Certain Inventive Embodiments" one will understand how illustrated features serve to explain certain principles of the present disclosure.

FIGS. 1 through 7 are cross-sectional views schematically illustrating processes of a method of manufacturing an organic light emitting display apparatus.

FIG. 8 is a photo schematically showing a part of the organic light emitting display apparatus illustrated in FIG. 6.

FIGS. 9 through 12 are cross-sectional views schematically illustrating processes of a method of manufacturing an organic light emitting display apparatus.

FIG. 13 is a cross-sectional view schematically illustrating an organic light emitting display apparatus that is manufactured by a method of manufacturing an organic light emitting display apparatus.

FIG. 14 is a cross-sectional view schematically illustrating one process of the method of manufacturing an organic light emitting display apparatus illustrated in FIG. 13.

FIGS. 15 through 18 are cross-sectional views schematically illustrating processes of a method of manufacturing an organic light emitting display apparatus.

FIGS. 19 through 21 are cross-sectional views schematically illustrating processes of a method of manufacturing an organic light emitting display apparatus.

FIG. 22 is a cross-sectional view schematically illustrating an organic light emitting display apparatus that is manufactured by a method of manufacturing an organic light emitting display apparatus.

FIGS. 23 through 26 are cross-sectional views schematically illustrating processes of a method of manufacturing an organic light emitting display apparatus.

FIGS. 27 through 29 are cross-sectional views schematically illustrating processes of a method of manufacturing an organic light emitting display apparatus.

FIG. 30 is a cross-sectional view schematically illustrating an organic light emitting display apparatus that is manufactured by a method of manufacturing an organic light emitting display apparatus.

FIG. 31 is cross-sectional view schematically illustrating process of a method of manufacturing an organic light emitting display apparatus.

FIG. 32 is cross-sectional view schematically illustrating process of a method of manufacturing an organic light emitting display apparatus.

DETAILED DESCRIPTION OF CERTAIN INVENTIVE EMBODIMENTS

Reference will now be made in detail to exemplary embodiments, examples of which are illustrated in the accompanying drawings. However, exemplary embodiments are not limited to the embodiments illustrated hereinafter, and the embodiments herein are rather introduced to provide easy and complete understanding of the scope and spirit of exemplary embodiments. In the drawings, elements may be exaggerated or reduced for conveniences of explanation. For example, the sizes and the thicknesses of elements are arbitrarily shown for convenience of explanation and thus, the present disclosure is not limited thereto. It will be understood that when an element, such as a layer, a region, or a substrate, is referred to as being "on", "connected to" or "coupled to" another element, it may be directly on, connected or coupled to the other element, or intervening elements may be present. As used herein, the term "and/or" includes any and all combinations of one or more of the associated listed items. Expressions such as "at least one of," when preceding a list of elements, modify the entire list of elements and do not modify the individual elements of the list.

FIGS. 1 through 7 are cross-sectional views schematically illustrating processes of a method of manufacturing an organic light emitting display apparatus, according to embodiments of the present disclosure.

First, in some embodiments as illustrated in FIG. 1, a pixel electrode 210 and a bus electrode 210a are formed on the same layer. The pixel electrode 210 and the bus electrode 210a are spaced apart and electrically insulated from each other. In FIG. 1, the pixel electrode 210 and the bus electrode 210a are formed on a planarization layer 170. However, aspects of the present disclosure are not limited thereto.

Prior to forming the pixel electrode 210 and the bus electrode 210a, various layers may be formed. In the drawings, a thin film transistor TFT and a capacitor Cap are formed on a substrate 100, the planarization layer 170 is formed to cover the thin film transistor TFT and the capacitor Cap, and then, the pixel electrode 210 and the bus electrode 210a are formed on the planarization layer 170.

The substrate 100 may be formed from one of various materials including a glass material, a metal material, and a plastic material, such as polyethylene terephthalate (PET), polyethylene naphthalate (PEN), or polyimide. A buffer layer 110 formed on the substrate 100 to prevent impurities from permeating a semiconductor layer of the thin film transistor TFT, a gate insulating layer 130 is formed on the buffer layer 110 to insulate the semiconductor layer and the gate electrode of the thin film transistor TFT from each other, an interlayer dielectric (ILD) layer 150 is formed on the gate insulating layer 130 to insulate a source electrode/drain electrode and the gate electrode of the thin film transistor TFT from each other, and the planarization layer 170 is formed on the interlayer dielectric (ILD) layer 150 to cover the thin film transistor TFT. The planarization layer 170 has an approximately flat top surface. Other elements may be formed on the buffer layer 110.

The pixel electrode 210 and the bus electrode 210a may be (semi-) transparent electrodes or reflection electrodes. When the pixel electrode 210 and the bus electrode 210a are (semi-)transparent electrodes, the pixel electrode 210 and the bus electrode 210a may be formed from, for example, an indium tin oxide (ITO), an indium zinc oxide (IZO), a zinc oxide (ZnO), an indium oxide (In₂O₃), an indium gallium oxide (IGO), or an aluminum zinc oxide (AZO). When the

pixel electrode **210** and the bus electrode **210a** are reflection electrodes, a reflection layer may be formed from Ag, Mg, Al, Pt, Pd, Au, Ni, Nd, Ir, Cr, or a combination thereof, and a layer formed from ITO, IZO, ZnO or In₂O₃ may be formed on the reflection layer. The pixel electrode **210** and the bus electrode **210a** may be simultaneously formed from the same material.

Subsequently, a pixel defining layer **180** is formed on the same layer as the pixel electrode **210** and the bus electrode **210a** so that at least a part of the pixel electrode **210** including a central part thereof and at least a part of the bus electrode **210a** may be exposed. The pixel defining layer **180** has an opening corresponding to each subpixel, for example, an opening through which at least a part of the pixel electrode **210** including the central part thereof is exposed, thereby defining pixels. The pixel defining layer **180** causes a distance between an end of the pixel electrode **210** and an opposite electrode (not shown) at an upper portion of the pixel electrode **210** that will be formed later to increase, thereby preventing an arc from occurring at the end of the pixel electrode **210**.

Subsequently, in some embodiments as illustrated in FIG. 2, a first intermediate layer **221** is formed on a top surface of the pixel defining layer **180** between the pixel electrode **210** and the bus electrode **210a**, the pixel electrode **210**, and the bus electrode **210a**. That is, the first intermediate layer **221** may be formed integrally in a plurality of pixels.

In some embodiments, the first intermediate layer **221** may have a single layer structure or a multi-layered structure. For example, when the first intermediate layer **221** is formed from a polymer material, the first intermediate layer **221** is a hole transport layer (HTL) having a single layer structure and may be formed from poly-(3,4)-ethylene-dihydroxy thiophene (PEDOT) or polyaniline (PANI). When the first intermediate layer **221** is formed from a low molecular material, the first intermediate layer **221** may include a hole injection layer (HIL) and a HTL.

Subsequently, as illustrated in FIG. 3, an emission layer (EML) **223** is formed on the first intermediate layer **221** to correspond to the pixel electrode **210**.

Subsequently, in some embodiments as illustrated in FIG. 4, a second intermediate layer **222** is formed to cover the first intermediate layer **221** and the emission layer (EML) **223**. Obviously, the second intermediate layer **222** is not necessarily formed, and for example, when the first intermediate layer **221** and the EML **223** are formed from a polymer material, the second intermediate layer **222** may not be formed. When the first intermediate layer **221** and the EML **223** are formed from a low molecular material, the second intermediate layer **222** may be formed so that an organic light emitting device has superior characteristics. In some embodiments, the second intermediate layer **222** may have a single layer structure or a multi-layered structure. The second intermediate layer **222** may include an electron transport layer (ETL) and/or an electron injection layer (EIL).

In some embodiments, after the second intermediate layer **222** is formed as illustrated in FIG. 6, a part of the first intermediate layer **221** on the bus electrode **210a** and a part of the second intermediate layer **222** on the bus electrode **210a** are removed so that a first opening **221'** of the first intermediate layer **221** and a second opening **222'** of the second intermediate layer **222** may be formed. As a result, at least a part of the bus electrode **210a** may be exposed. To this end, as illustrated in FIG. 5, a laser beam is irradiated onto the second intermediate layer **222** so that the first opening **221'** (a first hole) of the first intermediate layer **221**

and the second opening **222'** (a second hole) of the second intermediate layer **222** may be simultaneously formed.

Subsequently, in some embodiments as illustrated in FIG. 7, an opposite electrode **230** corresponding to the pixel electrode **210** and the bus electrode **210a** is formed to contact the bus electrode **210a** through the first opening **221'** of the first intermediate layer **221** and the second opening **222'** of the second intermediate layer **222**. The opposite electrode **230** may be formed as an integral part in a plurality of pixels and may cover a display region (active region). The display region means all regions of the entire organic light emitting display apparatus in which light may be emitted, for example, all regions excluding edges of the organic light emitting display apparatus in which a controller is to be disposed. Obviously, when a dead area does not exist in the entire surface of the organic light emitting display apparatus, the entire surface of the organic light emitting display apparatus may be the display region.

The opposite electrode **230** may contact electrode power supply lines outside the display region and may receive electrical signals from the electrode power supply lines. The opposite electrode **230** may be a (semi-)transparent electrode or a reflection electrode. When the opposite electrode **230** is a (semi-)transparent electrode, a layer may be formed from Li, Ca, LiF/Ca, LiF/Al, Al, Mg, or a combination thereof, a layer may be formed from a (semi-)transparent material, such as ITO, IZO, ZnO, or In₂O₃ on the layer so that the opposite electrode **230** may be formed as the (semi-)transparent electrode. When the opposite electrode **230** is a reflection electrode, a layer may be formed from at least one from among Li, Ca, LiF/Ca, LiF/Al, Al, Ag, and Mg so that the opposite electrode **230** may be formed as the reflection electrode. Obviously, the configuration and material of the opposite electrode **230** are not limited thereto, and various modifications like forming the opposite electrode **230** of other materials or forming the opposite electrode **230** to have a multi-layered structure are possible.

In the method of manufacturing the organic light emitting display apparatus according to the current embodiment of the present disclosure, after the bus electrode **210a** is formed, the opposite electrode **130** contacts the bus electrode **210a**, and electrical signals are transmitted to the opposite electrode **230** via the bus electrode **210a** having high electrical conductivity. Thus, an IR drop that may occur in the opposite electrode **230** when no bus electrode **210a** is present may be prevented or minimized. Thus, an unintended brightness difference may be prevented from being generated in the plurality of pixels, or even when the unintended brightness difference is generated, the brightness difference may be minimized.

To allow the opposite electrode **230** and the bus electrode **210a** to contact each other, as illustrated in FIG. 7, at least a part of the bus electrode **210a** need not be covered by the first intermediate layer **221** and the second intermediate layer **222**. To this end, from a time when the first intermediate layer **221** and the second intermediate layer **222** are initially formed, the first intermediate layer **221** and the second intermediate layer **222** may not be formed on at least a part of the bus electrode **210a**. However, in this case, a mask must be used to form the first intermediate layer **221** and the second intermediate layer **222**. Thus, a manufacturing process may be complicated when the mask and the substrate **100** need to be precisely aligned.

However, in the method of manufacturing the organic light emitting display apparatus according to the current embodiment of the present disclosure, the first intermediate layer **221** and the second intermediate layer **222** are formed

on the entire surface of the substrate **100**, and only portions of the first intermediate layer **221** and the second intermediate layer **222** on at least a part of the bus electrode **210a** are selectively removed using the laser beam so that manufacturing efficiency may be remarkably improved.

FIG. **8** is a photo schematically showing a part of the organic light emitting display apparatus illustrated in FIG. **6**. In some embodiments as illustrated in FIG. **8**, as the laser beam is irradiated onto the second intermediate layer **222**, portions of the first intermediate layer **221** and the second intermediate layer **222** are removed so that a part of the bus electrode **210a** may be exposed. As the laser beam is directly irradiated onto the second intermediate layer **222**, as illustrated in FIG. **8**, the second opening **222'** of the second intermediate layer **222** onto which the laser beam is directly irradiated may be larger than the first opening **221'** of the first intermediate layer **221**. In FIG. **8**, the first opening **221'** and the second opening **222'** have approximately circular shapes, and a radius $r2$ of the second opening **222'** may be larger than a radius $r1$ of the first opening **221'**.

As described above, if the second intermediate layer **222** is not formed, the laser beam is directly irradiated onto the first intermediate layer **221**, a part of the first intermediate layer **221** on the bus electrode **210a** is removed so that at least a part of the bus electrode **210a** may be exposed, thereby forming the first opening **221'**. When the opposite electrode **230** is formed, the opposite electrode **230** corresponding to the pixel electrode **210** and the bus electrode **210a** is formed to contact the bus electrode **210a** via the first opening **221'** of the first intermediate layer **221**.

When the first opening **221'** and/or the second opening **222'** is formed, as illustrated in FIG. **8**, only a part of the bus electrode **210a** may be exposed. For example, a plurality of first openings **221'** and/or second openings **222'** having approximately circular shapes as illustrated in FIG. **8** are formed in the display region of the organic light emitting display region so that the opposite electrode **230** may contact a plurality of the bus electrodes **210a**.

FIGS. **9** through **12** are cross-sectional views schematically illustrating processes of a method of manufacturing an organic light emitting display apparatus, according to other embodiments of the present disclosure.

In the method of manufacturing the organic light emitting display apparatus according to the current embodiment of the present disclosure, as described above with reference to FIGS. **1** through **4**, the second intermediate layer **222** is formed, and in some embodiments as illustrated in FIG. **9**, an auxiliary opposite electrode **231** corresponding to the pixel electrode **210** and the bus electrode **210a** is formed. That is, the auxiliary opposite electrode **231** is formed to cover the second intermediate layer **222**. If the second intermediate layer **222** is not formed, the auxiliary opposite electrode **231** may be formed to cover the first intermediate layer **221** and the EML **223**. A material for forming the auxiliary opposite electrode **231** may be one of the above-described materials used for forming the opposite electrode **230**, for example.

Subsequently, in some embodiments as illustrated in FIG. **10**, the laser beam is irradiated onto the auxiliary opposite electrode **231**, and the first opening **221'** of the first intermediate layer **221**, the second opening **222'** of the second intermediate layer **222**, and a third opening **231'** of the auxiliary opposite electrode **231** are simultaneously formed, in some embodiments as illustrated in FIG. **11**. Obviously, if the second intermediate layer **222** is not formed, the laser beam is irradiated onto the auxiliary opposite electrode **231** so that the first opening **221'** of the first intermediate layer

221 and the third opening **231'** of the auxiliary opposite electrode **231** may be simultaneously formed.

Subsequently, in some embodiments as illustrated in FIG. **12**, the opposite electrode **230** corresponding to the pixel electrode **210** and the bus electrode **210a** is formed to contact the bus electrode **210a** through the first opening **221'** of the first intermediate layer **221**, the second opening **222'** of the second intermediate layer **222**, and the third opening **231'** of the auxiliary opposite electrode **231**. Even in this case, the opposite electrode **230** may be formed as an integral part in the plurality of pixels and may cover the display region (active region).

In the method of manufacturing the organic light emitting display apparatus according to the present embodiment, the bus electrode **210a** is formed, and the opposite electrode **230** contacts the bus electrode **210a**, and electrical signals are transmitted to the opposite electrode **230** via the bus electrode **210a** having high electrical conductivity. Thus, an IR drop that may occur when no bus electrode **210a** is present may be prevented or minimized. Thus, an unintended brightness difference may be prevented from being generated in the plurality of pixels, or even when the unintended brightness difference is generated, the brightness difference may be minimized.

The first intermediate layer **221** and/or the second intermediate layer **222** is formed on the entire surface of the substrate **100**, and only portions of the first intermediate layer **221** and the second intermediate layer **222** on at least a part of the bus electrode **210a** are selectively removed using the laser beam to allow the opposite electrode **230** and the bus electrode **210a** to contact each other. Thus, manufacturing efficiency may be significantly improved when compared similar processes known in the art.

In the method of manufacturing the organic light emitting display apparatus according to the present embodiment, if the second intermediate layer **222** is not formed using the auxiliary opposite electrode **231**, the first intermediate layer **221** and the EML **223** are covered and then the laser beam is irradiated onto the auxiliary opposite electrode **231**. The laser beam is irradiated onto the auxiliary opposite electrode **231** in a state in which the first intermediate layer **221** that is vulnerable to an impurity from the outside, the second intermediate layer **222** and/or the EML **223** are covered with the auxiliary opposite electrode **231**. Thus, compared to the case when the laser beam is irradiated onto the first intermediate layer **221** and/or the second intermediate layer **222** without covering the auxiliary opposite electrode **231**, damage of the first intermediate layer **221**, the second intermediate layer **222** and/or the EML **223** may be minimized, and the occurrence of a manufacturing defect may be remarkably reduced.

In the method of manufacturing the organic light emitting display apparatus, the laser beam is irradiated onto the auxiliary opposite electrode **231**, thereby removing a part of the auxiliary opposite electrode **231**. Thus, the auxiliary opposite electrode **231** may be formed with a small thickness so that the part of the auxiliary opposite electrode **231** may be easily removed. If light generated in the EML **223** is irradiated to the outside through the substrate **100**, the opposite electrode **230** may be formed with a sufficient large thickness in consideration of electrical conductivity. As a result, the opposite electrode **230** may be formed thicker than the auxiliary opposite electrode **231**.

When the auxiliary opposite electrode **231** and the opposite electrode **230** are formed from the same material, a boundary between the auxiliary opposite electrode **231** and the opposite electrode **230** may not occur in a final product

according to a process condition. In some embodiments, the auxiliary opposite electrode **231** and the opposite electrode **230** may be referred to the opposite electrode **230**. As illustrated in FIG. **13**, a thickness t_1 of another portion of the opposite electrode **230**, for example, the thickness t_1 of a portion of the pixel electrode **210** is larger than the thickness t_2 of a portion of the opposite electrode **230** where the opposite electrode **230** contacts the bus electrode **210a**. This is because, in the portion of the pixel electrode **210**, the opposite electrode **230** is formed twice and in the portion of the bus electrode **210a**, the opposite electrode **230** is formed once.

FIG. **14** is a cross-sectional view schematically illustrating one process of the method of manufacturing an organic light emitting display apparatus illustrated in FIG. **13**. In the method of manufacturing the organic light emitting display apparatus illustrated in FIG. **13**, the first intermediate layer **221**, the EML **223** and/or the second intermediate layer **222** are formed as illustrated in FIG. **5**, and the opposite electrode **230** is formed on the entire surface of the display unit as illustrated in FIG. **14**. Next, a laser beam is irradiated onto at least a part of the opposite electrode **230** corresponding to the bus electrode **210a** so that at least a part of the first intermediate layer **221** and/or the second intermediate layer **222** between the opposite electrode **230** and the bus electrode **210a** is removed and the opposite electrode **230** and the bus electrode **210a** contact each other. At least a part of the first intermediate layer **221** and/or the second intermediate layer **222** between the opposite electrode **230** and the bus electrode **210a** is removed to generate heat in the opposite electrode **230** by the laser beam irradiated onto the opposite electrode **230** and to remove the first intermediate layer **221** and/or the second intermediate layer **222** between the opposite electrode **230** and the bus electrode **210a** due to heat.

Until now, the bus electrode **210a** that is disposed on the same layer as the pixel electrode **210** has been described. However, aspects of the present disclosure are not limited thereto. For example, the bus electrode **210a** may also be disposed on the same layer as one electrode of the thin film transistor TFT. Hereinafter, the latter case will be described.

FIGS. **15** through **18** are cross-sectional views schematically illustrating processes of a method of manufacturing an organic light emitting display apparatus.

First, as illustrated in FIG. **15**, a bus electrode AL is formed on a substrate **100**, and a planarization layer **170** is formed as an insulating layer that covers the bus electrode AL, and a pixel electrode **210** is formed on the planarization layer **170**, and then, a pixel defining layer **180** is formed on the planarization layer **170** so that at least a part of the pixel electrode **210** including a central part thereof may be exposed. In this case, the pixel defining layer **180** may be formed on the planarization layer **170** so that at least a part of the planarization layer **170** corresponding to the bus electrode AL may be exposed. The planarization layer **170** is illustrated in FIG. **15**. However, the planarization layer **170** may be replaced with an insulating layer, such as a planarized or unplanarized protection layer. This also applies to the following embodiments and modifications thereof.

When the bus electrode AL is formed, the bus electrode AL may be formed on the same layer as at least one of a source electrode, a drain electrode, and a gate electrode of the thin film transistor TFT. In FIG. **15**, the bus electrode AL is formed on the same layer as the source electrode and the drain electrode of the thin film transistor TFT, i.e., on an interlayer dielectric (ILD) layer **150**. Obviously, the bus

electrode AL may be simultaneously formed from the same material as the source electrode and the drain electrode of the thin film transistor TFT.

Subsequently, as illustrated in FIG. **16**, a first intermediate layer **221** is formed on the pixel defining layer **180** and the pixel electrode **210**, and an emission layer (EML) **223** is formed on the first intermediate layer **221** to correspond to the pixel electrode **210**. The first intermediate layer **221** may be formed as an integral part in a plurality of pixels. The first intermediate layer **221** may have a single layer structure or a multi-layered structure. For example, when the first intermediate layer **221** is formed from a polymer material, the first intermediate layer **221** may be a hole transport layer (HTL) having a single layer structure. When the first intermediate layer **221** is formed from a low molecular material, the first intermediate layer **221** may include a hole injection layer (HIL) and a HTL.

Subsequently, as illustrated in FIG. **16**, a second intermediate layer **222** is formed to cover the first intermediate layer **221** and the EML **223**. Obviously, the second intermediate layer **222** is not necessarily formed, and for example, when the first intermediate layer **221** and the EML **223** are formed from a polymer material, the second intermediate layer **222** may not be formed. When the first intermediate layer **221** and the EML **223** are formed from a low molecular material, the second intermediate layer **222** may be formed so that an organic light emitting device has superior characteristics. In this case, the second intermediate layer **222** may have a single layer structure or a multi-layered structure. The second intermediate layer **222** may include an electron transport layer (ETL) and/or an electron injection layer (EIL).

Subsequently, as illustrated in FIG. **17**, at least a part of the bus electrode AL is exposed. This may be performed by forming a bus electrode hole ALH of the planarization layer **170** and a first opening **221'** of the first intermediate layer **221** by removing a portion of the planarization layer **170** on the bus electrode AL and a portion of the first intermediate layer **221** on the bus electrode AL. Obviously, if the second intermediate layer **222** exists, as illustrated in FIG. **17**, a second opening **222'** of the second intermediate layer **222** is also formed. Exposing at least a part of the bus electrode AL in this way may be performed by irradiating a laser beam onto the first intermediate layer **221** or the second intermediate layer **222**. That is, the bus electrode hole ALH, the first opening **221'**, and the second opening **222'** may be simultaneously formed through laser beam irradiation.

Subsequently, as illustrated in FIG. **18**, an opposite electrode **230** is formed to correspond to the pixel electrode **210** and the bus electrode AL to contract the bus electrode AL through the bus electrode hole ALH, the first opening **221'**, and the second opening **222'**. The opposite electrode **230** may be formed as an integral part in a plurality of pixels and may cover a display region (active region).

When the first opening **221'** and/or the second opening **222'** are formed, only a part of the bus electrode AL may be exposed, as illustrated in FIG. **17**. For example, a plurality of first openings **221'** and/or second openings **222'** having approximately circular shapes illustrated in FIG. **17** are formed in a display region of the organic light emitting display apparatus so that the opposite electrode **230** may contact a plurality of the bus electrodes AL.

FIGS. **19** through **21** are cross-sectional views schematically illustrating processes of a method of manufacturing an organic light emitting display apparatus.

In the method of manufacturing an organic light emitting display apparatus according to the current embodiment of

the present disclosure, as described above with reference to FIG. 16, a second intermediate layer 222 is formed, and an auxiliary opposite electrode 231 corresponding to a pixel electrode 210 and a bus electrode AL is formed, as illustrated in FIG. 19. That is, the auxiliary opposite electrode 231 is formed to cover the second intermediate layer 222. If the second intermediate layer 222 is not formed, the auxiliary opposite electrode 231 may be formed to cover a first intermediate layer 221 and an EML 223. A material for forming the auxiliary opposite electrode 231 may be one of the above-described materials used for forming an opposite electrode 230, for example.

Subsequently, as illustrated in FIG. 20, a bus electrode hole ALH of a planarization layer 170, a first opening 221' of the first intermediate layer 221, a second opening 222' of the second intermediate layer 222, and a third opening 231' of the auxiliary opposite electrode 231 are simultaneously formed by irradiating a laser beam onto the auxiliary opposite electrode 231. Obviously, if the second intermediate layer 222 is not formed, the bus electrode hole ALH, the first opening 221', and the third opening 231' are simultaneously formed by irradiating a laser beam onto the auxiliary opposite electrode 231.

Subsequently, as illustrated in FIG. 21, the opposite electrode 230 is formed to correspond to the pixel electrode 210 and the bus electrode AL to contact a bus electrode 210a through the bus electrode hole ALH, the first opening 221', the second opening 222', and the third opening 231'. Obviously, even in this case, the opposite electrode 230 may be formed as an integral part in a plurality of pixels and may cover a display region (active region).

In the method of manufacturing an organic light emitting display apparatus, a part of the auxiliary opposite electrode 231 is removed by irradiating a laser beam onto the auxiliary opposite electrode 231. Thus, the auxiliary opposite electrode 231 may be formed with a small thickness so that the part of the auxiliary opposite electrode 231 may be easily removed. If light generated in the EML 223 is irradiated to the outside through a substrate 100, the opposite electrode 230 may be formed with a sufficient large thickness in consideration of electrical conductivity. As a result, the opposite electrode 230 may be formed thicker than the auxiliary opposite electrode 231.

When the auxiliary opposite electrode 231 and the opposite electrode 230 are formed from the same material, a boundary between the auxiliary opposite electrode 231 and the opposite electrode 230 may not occur in a final product according to a process condition. In this case, the auxiliary opposite electrode 231 and the opposite electrode 230 may be referred to the opposite electrode 230. As illustrated in FIG. 22, a thickness t1 of another portion of the opposite electrode 230, for example, the thickness t1 of a portion of the pixel electrode 210 is larger than the thickness t2 of a portion of the opposite electrode 230 where the opposite electrode 230 contacts the bus electrode AL. This is because, in the portion of the pixel electrode 210, the opposite electrode 230 is formed twice and in the portion of the bus electrode AL, the opposite electrode 230 is formed once.

FIGS. 23 through 26 are cross-sectional views schematically illustrating processes of a method of manufacturing an organic light emitting display apparatus.

In the method of manufacturing an organic light emitting display apparatus according to the current embodiment of the present disclosure, a bus electrode AL is formed on the same layer as a source electrode and a drain electrode of a thin film transistor TFT, and a planarization layer 170 is formed as an insulating layer that covers the thin film

transistor TFT and the bus electrode AL, and subsequently, as illustrated in FIG. 23, a bus electrode hole ALH is formed to expose at least a part of the bus electrode AL by removing at least a part of the planarization layer 170 corresponding to the bus electrode AL. In this case, forming the bus electrode hole ALH may be performed simultaneously with forming a contact hole in the planarization layer 170 for exposing a portion to be electrically coupled with a pixel electrode 210 between the source electrode and the drain electrode of the thin film transistor TFT.

Subsequently, the pixel electrode 210 is formed to be electrically coupled with the thin film transistor TFT via the contact hole, and a pixel defining layer 180 is formed on the planarization layer 170 so that at least a central part of the pixel electrode 210 may be exposed. In this case, as illustrated in FIG. 23, the pixel defining layer 180 may be formed so that at least a part of portions exposed through the bus electrode hole ALH of the bus electrode AL may be exposed.

Subsequently, as illustrated in FIG. 24, a first intermediate layer 221 is formed on the pixel defining layer 180, the pixel electrode 210, and the bus electrode AL, and an emission layer (EML) 223 is formed, and a second intermediate layer 222 is formed, as needed. A first opening 221' is formed by removing a portion of the first intermediate layer 221 on the bus electrode AL, and at least a part of the bus electrode AL is exposed, as illustrated in FIG. 25. If the second intermediate layer 222 also exists, obviously, a second opening 222' is also formed by removing a portion of the second intermediate layer 222 on the bus electrode AL so that at least a part of the bus electrode AL may be exposed. Forming the first opening 221' may be performed by irradiating a laser beam onto the first intermediate layer 221, and if the second opening 222' need to be formed, the first opening 221' and the second opening 222' may be simultaneously formed by irradiating a laser beam onto the first intermediate layer 221.

As illustrated in FIG. 26, an opposite electrode 230 is formed to correspond to the pixel electrode 210 and the bus electrode AL to contact the bus electrode AL through the bus electrode hole ALH, the first opening 221', and the second opening 222'. The opposite electrode 230 may be formed as an integral part in a plurality of pixels and may cover a display region (active region).

FIGS. 27 through 29 are cross-sectional views schematically illustrating processes of a method of manufacturing an organic light emitting display apparatus.

In the method of manufacturing an organic light emitting display apparatus according to the current embodiment of the present disclosure, as described above with reference to FIG. 24, a second intermediate layer 222 is formed, and an auxiliary opposite electrode 231 corresponding to a pixel electrode 210 and a bus electrode AL is formed, as illustrated in FIG. 27. That is, the auxiliary opposite electrode 231 is formed to cover the second intermediate layer 222. If the second intermediate layer 222 is not formed, the auxiliary opposite electrode 231 may be formed to cover a first intermediate layer 221 and an EML 223. A material for forming the auxiliary opposite electrode 231 may be one of the above-described materials used for forming an opposite electrode 230, for example.

Subsequently, as illustrated in FIG. 28, a first opening 221' of the first intermediate layer 221, a second opening 222' of the second intermediate layer 222, and a third opening 231' of the auxiliary opposite electrode 231 are simultaneously formed by irradiating a laser beam onto the auxiliary opposite electrode 231. Obviously, if the second intermediate layer 222 is not formed, the first opening 221' and the third

opening **231'** are simultaneously formed by irradiating a laser beam onto the auxiliary opposite electrode **231**.

Subsequently, as illustrated in FIG. **29**, the opposite electrode **230** is formed to correspond to the pixel electrode **210** and the bus electrode AL to contact a bus electrode **210a** through a bus electrode hole ALH, the first opening **221'**, the second opening **222'**, and the third opening **231'**. Obviously, even in this case, the opposite electrode **230** may be formed as an integral part in a plurality of pixels and may cover a display region (active region).

In the method of manufacturing an organic light emitting display apparatus, a part of the auxiliary opposite electrode **231** is removed by irradiating a laser beam onto the auxiliary opposite electrode **231**. Thus, the auxiliary opposite electrode **231** may be formed with a small thickness so that the part of the auxiliary opposite electrode **231** may be easily removed. If light generated in the EML **223** is irradiated to the outside through a substrate **100**, the opposite electrode **230** may be formed with a sufficient large thickness in consideration of electrical conductivity. As a result, the opposite electrode **230** may be formed thicker than the auxiliary opposite electrode **231**.

When the auxiliary opposite electrode **231** and the opposite electrode **230** are formed from the same material, a boundary between the auxiliary opposite electrode **231** and the opposite electrode **230** may not occur in a final product according to a process condition. In this case, the auxiliary opposite electrode **231** and the opposite electrode **230** may be referred to the opposite electrode **230**. As illustrated in FIG. **30**, a thickness t_1 of another portion of the opposite electrode **230**, for example, the thickness t_1 of a portion of the pixel electrode **210** is larger than the thickness t_2 of a portion of the opposite electrode **230** where the opposite electrode **230** contacts the bus electrode AL. This is because, in the portion of the pixel electrode **210**, the opposite electrode **230** is formed twice and in the portion of the bus electrode AL, the opposite electrode **230** is formed once.

FIG. **31** is cross-sectional view schematically illustrating process of a method of manufacturing an organic light emitting display apparatus. In the method of manufacturing an organic light emitting display apparatus according to the current embodiment of the present disclosure, as illustrated in FIG. **16**, the first intermediate layer **221**, the EML **223** and/or the second intermediate layer **222** are formed, and subsequently, as illustrated in FIG. **31**, an opposite electrode **230** is formed on the entire surface of a display unit. Next, a laser beam is irradiated onto at least a part of the opposite electrode **230** corresponding to a bus electrode AL so that layers between the opposite electrode **230** and the bus electrode AL are removed and the opposite electrode **230** and the bus electrode AL contact each other. Layers between the opposite electrode **230** and the bus electrode AL are removed to generate heat in the opposite electrode **230** by the laser beam irradiated onto the opposite electrode **230** and to remove the layers between the opposite electrode **230** and the bus electrode AL due to heat.

Obviously, if necessary, the first intermediate layer **221**, the EML **223**, the second intermediate layer **222**, and the opposite electrode **230** are formed, as illustrated in FIG. **32**, in a state in which the bus electrode hole ALH is formed, as illustrated in FIG. **24**, and subsequently, a laser beam is irradiated onto at least a part of the opposite electrode **230** corresponding to the bus electrode AL so that the first intermediate layer **221** and the second intermediate layer **222** between the opposite electrode **230** and the bus electrode AL may be removed and the opposite electrode **230** and the bus electrode AL may contact each other.

Until now, the method of manufacturing the organic light emitting display apparatus has been described. However, aspects of the present disclosure are not limited thereto. For example, the organic light emitting display apparatus manufactured using the method is also within the scope of the present disclosure.

For example, the organic light emitting display apparatus according to an embodiment of the present disclosure may have the configuration illustrated in FIG. **7**.

The organic light emitting display apparatus according to the present embodiment includes a pixel electrode **210** and a bus electrode **210a** formed on the same layer, are spaced apart and electrically insulated from each other, a pixel defining layer **180** formed on the same layer so that at least a part of the pixel electrode **210** including a central part thereof and at least a part of the bus electrode **210a** may be exposed, and an opposite electrode **230** formed corresponding to the pixel electrode **210** and the bus electrode **210a** and contacts the bus electrode **210a**.

The organic light emitting display apparatus according to the present embodiment further includes a first intermediate layer **221** and a second intermediate layer **222**. The first intermediate layer **221** and the second intermediate layer **222** are formed on a top surface of the pixel defining layer **180** between the pixel electrode **210** and the bus electrode **210a** and on the pixel electrode **210** and the bus electrode **210a**. Obviously, an emission layer (EML) **223** may be interposed between the first intermediate layer **221** and the second intermediate layer **222** to correspond to the pixel electrode **210**. In some embodiments, in order to allow the bus electrode **210a** and the opposite electrode **230** to contact each other, the first intermediate layer **221** and the second intermediate layer **222** have a first opening **221'** and a second opening **222'** in portions of the bus electrode **210a** so that at least a part of the bus electrode **210a** may be exposed. Obviously, the second intermediate layer **222** may not be formed depending on the occasion.

The organic light emitting display apparatus according to the present embodiment includes the bus electrode **210a**, and the opposite electrode **230** contacts the bus electrode **210a**. In operation electrical signals are transmitted to the opposite electrode **230** via the bus electrode **210a** having high electrical conductivity so that IR drop that may occur in the opposite electrode **230** when no bus electrode **210a** is present may be prevented or minimized. Thus, an unintended brightness difference may be prevented from being generated in the plurality of pixels, or even when the unintended brightness difference is generated, the brightness difference may be minimized.

As described above, to allow the opposite electrode **230** and the bus electrode **210a** to contact each other, the first intermediate layer **221** and/or the second intermediate layer **222** have the first opening **221'** and/or the second opening **222'** so that at least a part of the bus electrode **210a** may be exposed. The first opening **221'** or the second opening **222'** may be formed by forming the first intermediate layer **221** and/or the second intermediate layer **222** on the entire surface of the substrate **100**, by irradiating a laser beam onto predetermined portions of the first intermediate layer **221** and/or the second intermediate layer **222** and by removing at least a part of the portions onto which the laser beam is irradiated so that a manufacturing yield may be improved. Thus, in the organic light emitting display apparatus according to the present embodiment, a portion of the first intermediate layer **221** adjacent to the first opening **221'** may be a portion that has deteriorated by exposure to a high-

temperature heat. This also applies to the second opening 222' of the second intermediate layer 222.

FIG. 8 is a photo schematically showing a part of the organic light emitting display apparatus illustrated in FIG. 6. In some embodiments as illustrated in FIG. 8, as the laser beam may be irradiated onto the first intermediate layer 221 and the second intermediate layer 222, portions of the first intermediate layer 221 and the second intermediate layer 222 are removed so that a part of the bus electrode 210a may be exposed. As the laser beam is directly irradiated onto the second intermediate layer 222, as illustrated in FIG. 8, the second opening 222' of the second intermediate layer 222 onto which the laser beam is directly irradiated, is larger than the first opening 221' of the first intermediate layer 221. In FIG. 8, the first opening 221' and the second opening 222' have approximately circular shapes, and a radius r2 of the second opening 222' is larger than a radius r1 of the first opening 221'. The first opening 221' and the second opening 222' are simultaneously formed so that their centers are substantially aligned with each other when viewed in a direction substantially normal to each opening.

When the first opening 221' and/or the second opening 222' is formed, only a part of the bus electrode 210a may be exposed, as illustrated in FIG. 8. For example, a plurality of first openings 221' and/or second openings 222' having approximately circular shapes illustrated in FIG. 8 are formed in a display region of the organic light emitting display apparatus so that the opposite electrode 230 may contact a plurality of the bus electrodes 210a.

The first intermediate layer 221 and the EML 223 are very vulnerable to external impurities, such as moisture. Thus, if a portion of the first intermediate layer 221 is removed by irradiating the laser beam onto the first intermediate layer 221 in a state where only the first intermediate layer 221 and the EML 223 are formed without forming the second intermediate layer 222, the first intermediate layer 221 and the EML 223 may be damaged. Thus, the first opening 221' and the second opening 222' may be simultaneously formed by irradiating the laser beam onto the opposite electrode 230 after the second intermediate layer 222 has been formed. For example, when the second intermediate layer 222 includes at least one of LiF and Liq, an ohmic contact of the opposite electrode 230 may be smoothly performed. When the second intermediate layer 222 includes at least one of LiF and Liq, vulnerability to external impurities is improved, and damage of the first intermediate layer 221, the EML 223, and the second intermediate layer 222 may be efficiently prevented when the first opening 221' and the second opening 222' are formed by irradiating the laser beam onto the opposite electrode 230.

Obviously, in order to prevent damage of the first intermediate layer 221, the EML 223 and/or the second intermediate layer 222, after the opposite electrode 230 has been formed, the laser beam is irradiated onto at least a part of the opposite electrode 230 corresponding to the bus electrode 210a, and at least a part of the first intermediate layer 221 and/or the second intermediate layer 222 between the opposite electrode 230 and the bus electrode 210a is removed so that the opposite electrode 230 and the bus electrode 210a contact each other. Even in this case, the organic light emitting display apparatus may have the structure illustrated in FIG. 7.

An organic light emitting display apparatus according to another embodiment of the present disclosure may have the configuration illustrated in FIG. 12. That is, the organic light emitting display apparatus may further include an auxiliary opposite electrode 231 formed on a surface in a direction of

the first intermediate layer 221 of the opposite electrode 230 to contact the opposite electrode 230 and that has a third opening 231' corresponding to the first opening 221' of the first intermediate layer 221. That is, the auxiliary opposite electrode 231 may correspond to the opposite electrode 230 in a portion of the first intermediate layer 221 not including the first opening 221'. The organic light emitting display apparatus according to the present embodiment may prevent or minimize an IR drop of the opposite electrode 230 via the bus electrode 210a. When the first opening 221' and/or the second opening 222' is formed in the first intermediate layer 221 and/or the second intermediate layer 222, the first intermediate layer 221, the EML 223 and/or the second intermediate layer 222, which are formed below the auxiliary opposite electrode 231, are protected by the auxiliary opposite electrode 231 so that damage of the first intermediate layer 221, the EML 223 and/or the second intermediate layer 222 may be efficiently prevented. The thickness of the auxiliary opposite electrode 231 may be smaller than the thickness of the opposite electrode 230.

The auxiliary opposite electrode 231 and the opposite electrode 230 may be formed as an integral part in some embodiments as illustrated in FIG. 13. It will be understood that the thickness t2 of a portion of the opposite electrode 230 corresponding to the first opening 221' of the first intermediate layer 221 is smaller than the thickness t1 of another portion of the opposite electrode 230, for example, the thickness t1 of a portion of the pixel electrode 210.

An organic light emitting display apparatus according to another embodiment of the present disclosure may have the configuration illustrated in FIG. 18.

The organic light emitting display apparatus according to the current embodiment of the present disclosure includes a bus electrode AL, a planarization layer 170 that is an insulating layer covering the bus electrode AL and having a bus electrode hole ALH exposing at least a part of the bus electrode AL, a pixel defining layer 180 that is disposed on the planarization layer 170 and exposes at least a part of a pixel electrode 210 including a central part thereof and portions exposed through the bus electrode hole ALH, and an opposite electrode 230 that is disposed to correspond to the pixel electrode 210 and the bus electrode AL and contacts the bus electrode AL. The bus electrode AL may be disposed on the same layer as at least one of a source electrode, a drain electrode, and a gate electrode of a thin film transistor TFT. In FIG. 18, the source electrode and the drain electrode are located above the gate electrode, and the bus electrode AL is disposed on the same layer as the source electrode and the drain electrode.

Furthermore, the organic light emitting display apparatus according to the current embodiment of the present disclosure includes a first intermediate layer 221 and a second intermediate layer 222. The first intermediate layer 221 and the second intermediate layer 222 are disposed on the pixel defining layer 180 and the pixel electrode 210. Obviously, the first intermediate layer 221 and the second intermediate layer 222 may also be disposed on the planarization layer that is an insulating layer in the vicinity of the bus electrode hole ALH, as illustrated in FIG. 18. An emission layer (EML) 223 may be interposed between the first intermediate layer 221 and the second intermediate layer 222 to correspond to the pixel electrode 210. In this case, to allow the bus electrode AL and the opposite electrode 230 to contact each other, the first intermediate layer 221 and the second intermediate layer 222 have a first opening 221' and a second opening 222' in portions of the first intermediate layer 221 and the second intermediate layer 222 on the bus electrode

AL so that at least a part of the bus electrode AL may be exposed. Obviously, the second intermediate layer 222 may not exist, as occasion demands.

In the organic light emitting display apparatus according to the current embodiment of the present disclosure, the bus electrode AL is formed, and the opposite electrode 230 contacts the bus electrode AL, and electrical signals are transmitted to the opposite electrode 230 via the bus electrode AL having high electrical conductivity. Thus, an IR drop that may occur when no bus electrode AL is present may be prevented or minimized. Thus, an unintended brightness difference may be prevented from being generated in a plurality of pixels, or even when the unintended brightness difference is generated, the brightness difference may be minimized.

As described above, to allow the opposite electrode 230 and the bus electrode AL to contact each other, the first intermediate layer 221 and/or the second intermediate layer 222 have the first opening 221' and/or the second opening 222' in portions of the first intermediate layer 221 and/or the second intermediate layer 222 on the bus electrode AL so that at least a part of the bus electrode AL may be exposed. The first opening 221' or the second opening 222' may be formed by forming the first intermediate layer 221 and/or the second intermediate layer 222 on the entire surface of the substrate 100, by irradiating a laser beam onto predetermined portions of the first intermediate layer 221 and/or the second intermediate layer 222 and by removing at least a part of the portions onto which the laser beam is irradiated so that a manufacturing yield may be improved. Thus, in the organic light emitting display apparatus according to the present embodiment, a portion of the first intermediate layer 221 adjacent to the first opening 221' may be a portion that has deteriorated by exposure to a high-temperature heat. This also applies to the second opening 222' of the second intermediate layer 222.

When the first opening 221' and the second opening 222' are formed by irradiating a laser beam onto the first intermediate layer 221 and the second intermediate layer 222, as the laser beam is directly irradiated onto the second intermediate layer 222, the second opening 222' of the second intermediate layer 222 onto which the laser beam is directly irradiated, is larger than the first opening 221' of the first intermediate layer 221. In this case, the first opening 221' and the second opening 222' are simultaneously formed so that their centers are substantially aligned with each other when viewed in a direction substantially normal to each opening.

When the first opening 221' and/or the second opening 222' are formed, only a part of the bus electrode AL may be exposed, as illustrated in FIG. 18. For example, a plurality of first openings 221' and/or second openings 222' having approximately circular shapes are formed in a display region of the organic light emitting display apparatus so that the opposite electrode 230 may contact a plurality of the bus electrodes AL.

The first intermediate layer 221 and the EML 223 are very vulnerable to external impurities from the outside, such as moisture. Thus, if a portion of the first intermediate layer 221 is removed by irradiating the laser beam onto the first intermediate layer 221 in a state where only the first intermediate layer 221 and the EML 223 are formed without forming the second intermediate layer 222, the first intermediate layer 221 and the EML 223 may be damaged. Thus, the first opening 221' and the second opening 222' may be simultaneously formed by irradiating the laser beam onto the opposite electrode 230 after the second intermediate layer

222 has been formed. For example, when the second intermediate layer 222 includes at least one of LiF and Liq, an ohmic contact of the opposite electrode 230 may be smoothly performed. When the second intermediate layer 222 includes at least one of LiF and Liq, vulnerability to external impurities is improved, and damage of the first intermediate layer 221, the EML 223, and the second intermediate layer 222 may be efficiently prevented when the first opening 221' and the second opening 222' are formed by irradiating the laser beam onto the opposite electrode 230.

Obviously, in order to prevent damage of the first intermediate layer 221, the EML 223 and/or the second intermediate layer 222, after the opposite electrode 230 has been formed, the laser beam is irradiated onto at least a part of the opposite electrode 230 corresponding to the bus electrode AL, and at least a part of the first intermediate layer 221 and/or the second intermediate layer 222 between the opposite electrode 230 and the bus electrode AL is removed so that the opposite electrode 230 and the bus electrode AL contact each other. Even in this case, the organic light emitting display apparatus may have the structure illustrated in FIG. 18.

As described above, to allow the opposite electrode 230 and the bus electrode AL to contact each other, the first intermediate layer 221 and/or the second intermediate layer 222 have the first opening 221' and/or the second opening 222' in portions of the first intermediate layer 221 and/or the second intermediate layer 222 on the bus electrode AL so that at least a part of the bus electrode AL may be exposed. The first opening 221' or the second opening 222' may be formed by forming the first intermediate layer 221 and/or the second intermediate layer 222 on the entire surface of the substrate 100, by irradiating a laser beam onto predetermined portions of the first intermediate layer 221 and/or the second intermediate layer 222 and by removing at least a part of the portions onto which the laser beam is irradiated so that a manufacturing yield may be improved. Thus, in the organic light emitting display apparatus according to the present embodiment, a portion of the first intermediate layer 221 adjacent to the first opening 221' may be a portion that has deteriorated by exposure to a high-temperature heat. This also applies to the second opening 222' of the second intermediate layer 222.

An organic light emitting display apparatus according to another embodiment of the present disclosure may have the configuration illustrated in FIG. 21. That is, the organic light emitting display apparatus may further include an auxiliary opposite electrode 231 formed on a surface in a direction of the first intermediate layer 221 of the opposite electrode 230 to contact the opposite electrode 230 and that has a third opening 231' corresponding to the first opening 221' of the first intermediate layer 221. That is, the auxiliary opposite electrode 231 may correspond to the opposite electrode 230 in a portion of the first intermediate layer 221 not including the first opening 221'.

The organic light emitting display apparatus according to the present embodiment may prevent or minimize an IR drop of the opposite electrode 230 via the bus electrode AL. When the first opening 221' and/or the second opening 222' is formed in the first intermediate layer 221 and/or the second intermediate layer 222, the first intermediate layer 221, the EML 223 and/or the second intermediate layer 222, which are formed below the auxiliary opposite electrode 231, are protected by the auxiliary opposite electrode 231 so that damage of the first intermediate layer 221, the EML 223 and/or the second intermediate layer 222 may be efficiently

prevented. The thickness of the auxiliary opposite electrode **231** may be smaller than the thickness of the opposite electrode **230**.

The auxiliary opposite electrode **231** and the opposite electrode **230** may be formed as an integral part, as illustrated in FIG. **22**. In this case, it will be understood that the thickness t_2 of a portion of the opposite electrode **230** corresponding to the first opening **221'** of the first intermediate layer **221** is smaller than the thickness t_1 of another portion of the opposite electrode **230**, for example, the thickness t_1 of a portion of the pixel electrode **210**.

As described above, according to the one or more embodiments of the present disclosure, an organic light emitting display apparatus that can be easily manufactured and has high luminous stability and a method of manufacturing the same are provided. Obviously, the scope of the present disclosure is not limited by the effects.

While the present invention has been particularly shown and described with reference to exemplary embodiments thereof, it will be appreciated by those skilled in the art that various modifications and changes may be made without departing from the scope of the present disclosure. It will also be appreciated by those of skill in the art that parts included in one embodiment are interchangeable with other embodiments; one or more parts from a depicted embodiment can be included with other depicted embodiments in any combination. For example, any of the various components described herein and/or depicted in the Figures may be combined, interchanged or excluded from other embodiments. With respect to the use of substantially any plural and/or singular terms herein, those having skill in the art can translate from the plural to the singular and/or from the singular to the plural as is appropriate to the context and/or application. The various singular/plural permutations may be expressly set forth herein for sake of clarity. Thus, while the present disclosure has described certain exemplary embodiments, it will be understood by those of ordinary skill in the art that various changes in form and details may be made therein without departing from the spirit and scope of the present invention as defined by the following claims.

What is claimed is:

1. An organic light emitting display apparatus including plurality of pixels, the organic light emitting display apparatus comprising:

- a bus electrode;
- an insulating layer covering the bus electrode and having a bus electrode hole so that at least a part of the bus electrode is exposed through the bus electrode hole;
- a pixel electrode on the insulating layer and electrically insulated from the bus electrode;
- a pixel defining layer on the insulating layer so that at least the part of the bus electrode corresponding to the bus electrode hole and at least a part of the pixel electrode including a central part thereof are exposed;
- a first intermediate layer on the pixel defining layer and the pixel electrode, the first intermediate layer being formed integrally through the plurality of pixels, the first intermediate having a first hole corresponding to the bus electrode hole of the insulating layer so that at least the part of the bus electrode is exposed;
- an emission layer on the first intermediate layer corresponding to the pixel electrode; and
- an opposite electrode on the emission layer to correspond to the pixel electrode and the bus electrode, the opposite electrode contacting the bus electrode through the first hole of the first intermediate layer and the bus electrode hole of the insulating layer.

2. The organic light emitting display apparatus of claim **1**, further comprising a thin film transistor including a source electrode, a drain electrode, and a gate electrode, wherein the bus electrode is on a same layer as at least one of the source electrode, the drain electrode, and the gate electrode.

3. The organic light emitting display apparatus of claim **2**, wherein the source electrode and the drain electrode are located above the gate electrode, and the bus electrode is on a same layer as the source electrode and the drain electrode.

4. The organic light emitting display apparatus of claim **1**, wherein the first hole of the first intermediate layer exposes only a part of the bus electrode.

5. The organic light emitting display apparatus of claim **1**, wherein a portion of the first intermediate layer adjacent to the first hole is a portion that has deteriorated from exposure to heat.

6. The organic light emitting display apparatus of claim **1**, further comprising an auxiliary opposite electrode between the first intermediate layer and the opposite electrode, the auxiliary opposite electrode contacting the opposite electrode, the auxiliary opposite electrode having a third opening corresponding to the first hole of the first intermediate layer.

7. The organic light emitting display apparatus of claim **6**, wherein a thickness of the auxiliary opposite electrode is smaller than the thickness of the opposite electrode.

8. The organic light emitting display apparatus of claim **6**, wherein the auxiliary opposite electrode corresponds to the opposite electrode except a portion of the opposite electrode corresponding to the first opening.

9. The organic light emitting display apparatus of claim **1**, wherein a thickness of a portion of the opposite electrode corresponding to the first hole of the first intermediate layer is smaller than the thickness of another portion of the opposite electrode.

10. The organic light emitting display apparatus of claim **1**, further comprising a second intermediate layer between the first intermediate layer and the opposite electrode to cover the first intermediate layer and the emission layer, the second intermediate layer having a second hole corresponding to the first hole of the first intermediate layer so that the opposite electrode contacts the bus electrode through the first hole and the second hole.

11. The organic light emitting display apparatus of claim **10**, wherein the second hole is larger than the first opening.

12. The organic light emitting display apparatus of claim **11**, wherein a center of the second hole and a center of the first hole are substantially aligned with each other when viewed from a direction normal to both the first hole and the second hole.

13. The organic light emitting display apparatus of claim **10**, wherein a portion of the second intermediate layer adjacent to the second hole is a portion deteriorated from heat exposure.

14. The organic light emitting display apparatus of claim **10**, wherein the second intermediate layer includes at least one of LiF and Liq.

15. A method of manufacturing an organic light emitting display apparatus including a plurality of pixels, the method comprising:

- forming a bus electrode;
- forming an insulating layer covering the bus electrode;
- forming a pixel electrode on the insulating layer;
- forming a pixel defining layer on the insulating layer so that at least a part of the pixel electrode including a central part thereof is exposed;

23

forming a first intermediate layer on the pixel defining layer and the pixel electrode, the first intermediate layer being formed integrally through the plurality of pixels; forming an emission layer on the first intermediate layer corresponding to the pixel electrode;

exposing at least a part of the bus electrode through at least a first hole of the first intermediate layer, the first hole corresponding to the bus electrode; and

forming an opposite electrode corresponding to the pixel electrode and the bus electrode to contact the bus electrode.

16. The method of claim 15, wherein the forming of the bus electrode comprises forming the bus electrode on a same layer as at least one of a source electrode, a drain electrode, and a gate electrode of a thin film transistor.

17. The method of claim 15, further comprising forming a bus electrode hole exposing at least the part of the bus electrode by removing at least a portion of the insulating layer corresponding to the bus electrode,

wherein the forming of the pixel defining layer comprises forming the pixel defining layer on the insulating layer so that at least the part of the bus electrode exposed through the bus electrode hole is exposed;

wherein the forming of the first intermediate layer comprises forming the first intermediate layer on the pixel defining layer, the pixel electrode, and the bus electrode; and

wherein the exposing at least the part of the bus electrode comprises forming the first hole by removing a portion of the first intermediate layer on the bus electrode.

18. The method of claim 17, wherein the forming of the first hole comprises forming the first hole through which only a part of the bus electrode is exposed.

19. The method of claim 17, wherein the forming of the first hole includes irradiating a laser beam onto the first intermediate layer.

20. The method of claim 17, further comprising, after the forming of the emission layer and before the forming of the first opening, forming an auxiliary opposite electrode corresponding to the pixel electrode and the bus electrode,

wherein the first hole in the first intermediate layer is formed along with a third opening in the auxiliary opposite electrode by removing a portion of the first intermediate layer on the bus electrode and a portion of the auxiliary opposite electrode on the bus electrode to expose at least a part of the bus electrode; and

wherein the opposite electrode is formed to correspond to the pixel electrode and the bus electrode to contact the bus electrode through the first hole in the first intermediate layer and the third opening in the auxiliary opposite electrode.

21. The method of claim 20, wherein the first hole in the first intermediate layer and the third opening in the auxiliary opposite electrode are simultaneously formed by irradiating a laser beam onto the auxiliary opposite electrode.

22. The method of claim 20, wherein the opposite electrode is formed to be thicker than the auxiliary opposite electrode.

23. The method of claim 17, further comprising, after the forming of the emission layer and before the forming of the first opening, forming a second intermediate layer to cover the first intermediate layer and the emission layer,

wherein the first hole in the first intermediate layer is formed along with a second hole in the second intermediate layer by removing a portion of the first intermediate layer on the bus electrode and a portion of the

24

second intermediate layer on the bus electrode so that at least a part of the bus electrode is exposed; and wherein the opposite electrode is formed to correspond to the pixel electrode and the bus electrode to contact the bus electrode through the first hole of the first intermediate layer and the second hole of the second intermediate layer.

24. The method of claim 23, wherein the first hole in the first intermediate layer and the second hole in the second intermediate layer are simultaneously formed by irradiating a laser beam onto the second intermediate layer.

25. The method of claim 15, wherein the forming of the pixel defining layer comprises forming the pixel defining layer on the insulating layer so that at least the part of the pixel electrode including the central part thereof and at least a part of the insulating layer corresponding to the bus electrode are exposed, and

wherein the exposing at least the part of the bus electrode comprises forming a bus electrode hole of the insulating layer and the first hole of the first intermediate layer by removing a portion of the insulating layer on the bus electrode and a portion of the first intermediate layer on the bus electrode so that at least the part of the bus electrode is exposed.

26. The method of claim 25, wherein the forming of the bus electrode hole and the first hole comprises irradiating a laser beam onto the first intermediate layer.

27. The method of claim 25, further comprising after the forming of the emission layer and before the forming of the bus electrode hole and the first opening, forming an auxiliary opposite electrode corresponding to the pixel electrode and the bus electrode,

wherein the forming of the bus electrode hole and the first hole comprises forming a bus electrode hole of the insulating layer, a first hole of the first intermediate layer, and a third opening of the auxiliary opposite electrode by removing a portion of the insulating layer on the bus electrode, a portion of the first intermediate layer on the bus electrode, and a portion of the auxiliary opposite electrode on the bus electrode so that at least the part of the bus electrode is exposed; and wherein the forming of the opposite electrode comprises forming the opposite electrode to correspond to the pixel electrode and the bus electrode to contact the bus electrode through the bus electrode hole in the insulating layer, the first hole in the first intermediate layer, and the third opening in the auxiliary opposite electrode.

28. The method of claim 27, wherein the forming of the bus electrode hole, the first opening, and the third opening comprises irradiating a laser beam onto the auxiliary opposite electrode so that the bus electrode hole, the first opening, and the third opening are simultaneously formed.

29. The method of claim 27, wherein the opposite electrode is formed to be thicker than the auxiliary opposite electrode.

30. The method of claim 25, further comprising, after the forming of the emission layer and before the forming of the first opening, forming a second intermediate layer to cover the first intermediate layer and the emission layer,

wherein the forming of the bus electrode hole and the first hole comprises forming a bus electrode hole of the insulating layer, a first hole of the first intermediate layer, and a second hole of the second intermediate layer by removing a portion of the insulating layer on the bus electrode, a portion of the first intermediate layer on the bus electrode, and a portion of the second

25

intermediate layer on the bus electrode so that at least the part of the bus electrode is exposed; and wherein the forming of the opposite electrode comprises forming the opposite electrode to correspond to the pixel electrode and the bus electrode to contact the bus electrode through the bus electrode hole in the insulating layer, the first hole in the first intermediate layer, and the second hole in the second intermediate layer.

31. The method of claim 30, wherein the forming of the bus electrode hole, the first opening, and the second hole comprises irradiating a laser beam onto the second intermediate layer so that the bus electrode hole, the first opening, and the second hole are simultaneously formed.

32. A method of manufacturing an organic light emitting display apparatus including a plurality of pixels, the method comprising:

- forming a bus electrode;
- forming an insulating layer covering the bus electrode;

26

forming a pixel electrode on the insulating layer; forming a pixel defining layer on the insulating layer so that at least a part of the pixel electrode including a central part thereof is exposed; forming a first intermediate layer on the pixel defining layer and the pixel electrode, the first intermediate layer being formed integrally through the plurality of pixels; forming an emission layer on the first intermediate layer corresponding to the pixel electrode; forming an opposite electrode to correspond to the pixel electrode and the bus electrode; and irradiating a laser beam onto at least a part of the opposite electrode corresponding to the bus electrode so that at least a part of layers between the opposite electrode and the bus electrode is removed to form a hole and the opposite electrode and the bus electrode contact each other through the hole.

* * * * *

专利名称(译)	有机发光显示装置及其制造方法		
公开(公告)号	US9450039	公开(公告)日	2016-09-20
申请号	US14/479047	申请日	2014-09-05
[标]申请(专利权)人(译)	三星显示有限公司		
申请(专利权)人(译)	三星DISPLAY CO. , LTD.		
当前申请(专利权)人(译)	三星DISPLAY CO. , LTD.		
[标]发明人	JEONG BYOUNG SEONG KIM SANG YEOL CHANG SEUNG WOOK LEE SE HO KIM TAE HYUNG		
发明人	JEONG, BYOUNG-SEONG KIM, SANG-YEOL CHANG, SEUNG-WOOK LEE, SE-HO KIM, TAE-HYUNG		
IPC分类号	H01L27/32 H01L51/52		
CPC分类号	H01L27/3276 H01L27/3246 H01L51/5228 H01L27/1255 H01L27/3262 H01L27/3265 H01L51/0023 H01L51/56 H01L2227/323		
代理机构(译)	KNOBBE , MARTENS , 奥尔森 & BEAR LLP		
优先权	1020130063082 2013-05-31 KR 1020140066528 2014-05-30 KR		
其他公开文献	US20140374732A1		
外部链接	Espacenet USPTO		

摘要(译)

公开了一种有机发光显示装置及其制造方法。有机发光显示装置包括例如汇流电极，覆盖汇流电极并具有暴露汇流电极的至少一部分的汇流电极孔的绝缘层，形成在绝缘层上并与之电耦合的像素电极。总线电极，暴露部分像素电极和部分总线电极的像素限定层，像素限定层和像素电极上的第一中间层，第一中间层具有第一开口以暴露部分所述汇流电极，设置在所述第一中间层上的发光层，以及与所述像素电极和所述汇流电极对应并通过所述第一开口和所述汇流电极孔与所述汇流电极接触的相对电极。

